

FIXED FURNITURE BOQ FOR INDIAN EMBASSY WARSAW											
FIRST SECRETARY RESIDENCE CUPBOARDS											
S.N.	DESCRIPTIONS	CB'S NAMES	FLOOR	ROOM-NO	SIZE			QUANTITY	AREA	RATE(€)	AMOUNT(€)
					WIDTH	DEPTH	HEIGHT		SQM		
1	CB-1- Wardrobe, furniture board laminated body, 18 mm MDF fronts 19 mm thick opaque matt lacquered drawers with full extension ballbearing quiet, internal hinges Blum clips, metal handles, satin, brakes doors, baseboards painted.	CB-1	F.F.	2A/7, 2B/7	3.75	0.6	2.75	2	20.625		
2	CB-2- Wardrobe, furniture board laminated body, 18 mm MDF fronts 19 mm thick opaque matt lacquered drawers with full extension ballbearing quiet, internal hinges Blum clips, metal handles, satin, brakes doors, baseboards painted.	CB-2	F.F.	2A/3, 2B/3	1.62	0.3	2.1	2	6.804		
3	CB-2A- Wardrobe, furniture board laminated body, 18 mm MDF fronts 19 mm thick opaque matt lacquered drawers with full extension ballbearing quiet, internal hinges Blum clips, metal handles, satin, brakes doors, baseboards painted.	CB-2A	F.F.	2A/3, 2B/3	1.55	0.5	2.75	2	8.525		
4	CB-3- Wardrobe, furniture board laminated body,, 18 mm MDF fronts 19 mm thick opaque matt lacquered drawers with full extension ballbearing quiet, internal hinges Blum clips, metal handles, satin, brakes doors, baseboards painted.	CB-3	F.F.	2A/5, 2B/5	1.8	0.6	2.75	2	9.9		
5	CB-4- Wardrobe, furniture board laminated body,, 18 mm MDF fronts 19 mm thick opaque matt lacquered drawers with full extension ballbearing quiet, internal hinges Blum clips, metal handles, satin, brakes doors, baseboards painted.	CB-4	G.F.	1.A/7, 1.B/7	2.0	0.485	2.75	2	11		
Total front face area of F.S Cupboards									56.854		

STAFF RESIDENCE CUPBOARDS											
S.N.	DESCRIPTIONS	CB'S NAMES	FLOOR	ROOM-NO	SIZE			QUANTITY	AREA	RATE(€)	AMOUNT(€)
					WIDTH	DEPTH	HEIGHT		SQM		
1	CB-1- Wardrobe, furniture board laminated body, 18 mm MDF fronts 19 mm thick opaque matt lacquered drawers with full extension ballbearing quiet, internal hinges Blum clips, metal handles, satin, brakes doors, baseboards painted.	CB-1	G.F.	1/2.8 ,1/3.8	1.49	0.6	2.75	2	8.195		
			S.F.	3/8.8, 3/ 9.8	1.49	0.6	2.75	2	8.195		
2	CB-2- Wardrobe, furniture board laminated body, 18 mm MDF fronts 19 mm thick opaque matt lacquered drawers with full extension ballbearing quiet, internal hinges Blum clips, metal handles, satin, brakes doors, baseboards painted.	CB-2	G.F.	1/2.5 ,1/3.5	1.485	0.6	2.75	2	8.1675		
			F.F.	2/5.5, 2/6.53	1.485	0.6	2.75	2	8.1675		
			S.F.	8.5, 3/ 9.5	1.485	0.6	2.75	2	8.1675		
3	CB-2A- Wardrobe, furniture board laminated body, 18 mm MDF fronts 19 mm thick opaque matt lacquered drawers with full extension ballbearing quiet, internal hinges Blum clips, metal handles, satin, brakes doors, baseboards painted.	CB-2A	G.F.	1/2.4 ,1/3.4	1.35	0.38	2.75	2	7.425		
			F.F.	2/5.4, 2/6.4	1.35	0.38	2.75	2	7.425		
			S.F.	3/8.4, 3/ 9.4	1.35	0.38	2.75	2	7.425		
4	CB-3- Wardrobe, furniture board laminated body, 18 mm MDF fronts 19 mm thick opaque matt lacquered drawers with full extension ballbearing quiet, internal hinges Blum clips, metal handles, satin, brakes doors, baseboards painted.	CB-3	G.F.	1/1.7	1.8	0.6	2.75	1	4.95		
			F.F.	2/5.8 , 2/6.8	1.8	0.6	2.75	2	9.9		
5	CB-4- Wardrobe, furniture board laminated body, 18 mm MDF fronts 19 mm thick opaque matt lacquered drawers with full extension ballbearing quiet, internal hinges Blum clips, metal handles, satin, brakes doors, baseboards painted.	CB-4	G.F.	1/1.9	1.8	0.6	2.75	1	4.95		
6	CB-5- Wardrobe, furniture board laminated body, 18 mm MDF fronts 19 mm thick opaque matt lacquered drawers with full extension ballbearing quiet, internal hinges Blum clips, metal handles, satin, brakes doors, baseboards painted.	CB-5	G.F.	1/1.10	1.945	0.6	2.75	1	5.34875		

STAFF RESIDENCE CUPBOARDS											
S.N.	DESCRIPTIONS	CB'S NAMES	FLOOR	ROOM-NO	SIZE			QUANTITY	AREA	RATE(€)	AMOUNT(€)
					WIDTH	DEPTH	HEIGHT		SQM		
7	CB-6- Wardrobe, furniture board laminated body, 18 mm MDF fronts 19 mm thick opaque matt lacquered drawers with full extension ballbearing quiet, internal hinges Blum clips, metal handles, satin, brakes doors, baseboards painted.	CB-6	F.F.	2/4.8, 2/7.8	1.63	0.6	2.75	2	8.965		
8	CB-7- Wardrobe, furniture board laminated body, 18 mm MDF fronts 19 mm thick opaque matt lacquered drawers with full extension ballbearing quiet, internal hinges Blum clips, metal handles, satin, brakes doors, baseboards painted.	CB-7	F.F.	2/4.5, 2/7.5	1.55	0.6	2.75	2	8.525		
9	CB-7A- Wardrobe, furniture board laminated body, 18 mm MDF fronts 19 mm thick opaque matt lacquered drawers with full extension ballbearing quiet, internal hinges Blum clips, metal handles, satin, brakes doors, baseboards painted.	CB-7A	F.F.	2/4.4, 2/7.4	1.35	0.6	2.75	2	7.425		
10	CB-L1- Wardrobe, furniture board laminated body, 18 mm MDF fronts 19 mm thick opaque matt lacquered drawers with full extension ballbearing quiet, internal hinges Blum clips, metal handles, satin, brakes doors, baseboards painted.	CB-L1	F.F.	2/4.2, 2/7.2	2.34	0.45	2.12	2	9.922		
11	CB-L2- Wardrobe, furniture board laminated body, 18 mm MDF fronts 19 mm thick opaque matt lacquered drawers with full extension ballbearing quiet, internal hinges Blum clips, metal handles, satin, brakes doors, baseboards painted.	CB-L2	G.F.	1/1.3,1/2.2,1/3.2	4.25	0.45	2.12	3	27.03		
			F.F.	2/5.2, 2/6.2	4.25	0.45	2.12	2	18.02		
			S.F.	3/8.2, 3/ 9.2	4.25	0.45	2.12	2	18.02		

STAFF RESIDENCE CUPBOARDS											
S.N.	DESCRIPTIONS	CB'S NAMES	FLOOR	ROOM-NO	SIZE			QUANTITY	AREA	RATE(€)	AMOUNT(€)
					WIDTH	DEPTH	HEIGHT		SQM		
12	CB-1.1.1- Wardrobe, furniture board laminated body, 18 mm MDF fronts 19 mm thick opaque matt lacquered drawers with full extension ballbearing quiet, internal hinges Blum clips, metal handles, satin, brakes doors, baseboards painted.	CB-1.1.1	G.F.	1/1.1	1.47	0.46	2.75	1	4.0425		
13	CB-1.1.2- Wardrobe, furniture board laminated body, 18 mm MDF fronts 19 mm thick opaque matt lacquered drawers with full extension ballbearing quiet, internal hinges Blum clips, metal handles, satin, brakes doors, baseboards painted.	CB-1.1.2	G.F.	1/1.2	1.24	0.43	2.75	1	3.41		
14	CB-1.1.5- Wardrobe, furniture board laminated body, 18 mm MDF fronts 19 mm thick opaque matt lacquered drawers with full extension ballbearing quiet, internal hinges Blum clips, metal handles, satin, brakes doors, baseboards painted.	CB-1.1.5	G.F.	1/1.5	1.89	0.43	2.75	1	5.1975		
15	CB-1.2.1- Wardrobe, furniture board laminated body, 18 mm MDF fronts 19 mm thick opaque matt lacquered drawers with full extension ballbearing quiet, internal hinges Blum clips, metal handles, satin, brakes doors, baseboards painted.	CB-1.2.1	G.F.	1/2.1	1.46	0.6	2.75	1	4.015		
16	CB-1.3.1- Wardrobe, furniture board laminated body, 18 mm MDF fronts 19 mm thick opaque matt lacquered drawers with full extension ballbearing quiet, internal hinges Blum clips, metal handles, satin, brakes doors, baseboards painted.	CB-1.3.1	G.F.	1/3.1	1.46	0.6	2.75	1	4.015		
17	CB-1.3.3- Wardrobe, furniture board laminated body, 18 mm MDF fronts 19 mm thick opaque matt lacquered drawers with full extension ballbearing quiet, internal hinges Blum clips, metal handles, satin, brakes doors, baseboards painted.	CB-1.3.3	G.F.	1/3.3	1.14	0.35	2.1	1	2.394		

STAFF RESIDENCE CUPBOARDS											
S.N.	DESCRIPTIONS	CB'S NAMES	FLOOR	ROOM-NO	SIZE			QUANTITY	AREA	RATE(€)	AMOUNT(€)
					WIDTH	DEPTH	HEIGHT		SQM		
18	CB-1/3.3- Wardrobe, furniture board laminated body, 18 mm MDF fronts 19 mm thick opaque matt lacquered drawers with full extension ballbearing quiet, internal hinges Blum clips, metal handles, satin, brakes doors, baseboards painted.	CB-1/3.3	F.F.	1/3.3	1.14	0.51	2.1	1	2.394		
19	CB-1/4.3- Wardrobe, furniture board laminated body, 18 mm MDF fronts 19 mm thick opaque matt lacquered drawers with full extension ballbearing quiet, internal hinges Blum clips, metal handles, satin, brakes doors, baseboards painted.	CB-1/4.3	F.F.	1/4.3	1.14	0.51	2.1	1	2.394		
20	CB-2/4.1- Wardrobe, furniture board laminated body, 18 mm MDF fronts 19 mm thick opaque matt lacquered drawers with full extension ballbearing quiet, internal hinges Blum clips, metal handles, satin, brakes doors, baseboards painted.	CB-2/4.1	F.F.	2/4.1	1.85	0.6	2.75	1	5.0875		
21	CB-2/5.1- Wardrobe, furniture board laminated body, 18 mm MDF fronts 19 mm thick opaque matt lacquered drawers with full extension ballbearing quiet, internal hinges Blum clips, metal handles, satin, brakes doors, baseboards painted.	CB-2/5.1	F.F.	2/5.1	1.46	0.6	2.75	1	4.015		
22	CB-2/5.3- Wardrobe, furniture board laminated body, 18 mm MDF fronts 19 mm thick opaque matt lacquered drawers with full extension ballbearing quiet, internal hinges Blum clips, metal handles, satin, brakes doors, baseboards painted.	CB-2/5.3	F.F.	2/5.3	1.14	0.51	2.1	1	2.394		
23	CB-2/6.1- Wardrobe, furniture board laminated body, 18 mm MDF fronts 19 mm thick opaque matt lacquered drawers with full extension ballbearing quiet, internal hinges Blum clips, metal handles, satin, brakes doors, baseboards painted.	CB-2/6.1	F.F.	2/6.1	1.46	0.6	2.75	1	4.015		

STAFF RESIDENCE CUPBOARDS											
S.N.	DESCRIPTIONS	CB'S NAMES	FLOOR	ROOM-NO	SIZE			QUANTITY	AREA	RATE(€)	AMOUNT(€)
					WIDTH	DEPTH	HEIGHT		SQM		
24	CB-2/7.1- Wardrobe, furniture board laminated body, 18 mm MDF fronts 19 mm thick opaque matt lacquered drawers with full extension ballbearing quiet, internal hinges Blum clips, metal handles, satin, brakes doors, baseboards painted.	CB-2/7.1	F.F.	2/7.1	1.83	0.6	2.75	1	5.0325		
25	CB-2/7.3- Wardrobe, furniture board laminated body, 18 mm MDF fronts 19 mm thick opaque matt lacquered drawers with full extension ballbearing quiet, internal hinges Blum clips, metal handles, satin, brakes doors, baseboards painted.	CB-2/7.3	F.F.	2/7.3	1.12	0.33	2.1	1	2.352		
26	CB-3/8.1- Wardrobe, furniture board laminated body, 18 mm MDF fronts 19 mm thick opaque matt lacquered drawers with full extension ballbearing quiet, internal hinges Blum clips, metal handles, satin, brakes doors, baseboards painted.	CB-3/8.1	S.F.	3/8.1	1.46	0.6	2.75	1	4.015		
27	CB-3/8.3- Wardrobe, furniture board laminated body, 18 mm MDF fronts 19 mm thick opaque matt lacquered drawers with full extension ballbearing quiet, internal hinges Blum clips, metal handles, satin, brakes doors, baseboards painted.	CB-3/8.3	S.F.	3/8.3	0.94	0.515	2.1	1	1.974		
28	CB-3/9.1- Wardrobe, furniture board laminated body, 18 mm MDF fronts 19 mm thick opaque matt lacquered drawers with full extension ballbearing quiet, internal hinges Blum clips, metal handles, satin, brakes doors, baseboards painted.	CB-3/9.1	S.F.	3/9.1	1.46	0.6	2.75	1	4.015		
29	CB-3/9.3- Wardrobe, furniture board laminated body, 18 mm MDF fronts 19 mm thick opaque matt lacquered drawers with full extension ballbearing quiet, internal hinges Blum clips, metal handles, satin, brakes doors, baseboards painted.	CB-3/9.3	S.F.	3/9.3	0.94	0.515	2.1	1	1.974		
Total front face area of Staff residences Cupboards									248.959		

FIXED FURNITRES BOQ FOR INDIAN EMBASSY WARSAW						
MAIN BUILDING KITCHEN/PANTRY						
S.N.	DESCRIPTIONS	KITCHEN /PANTRY	ROOM NO.	QUANTITY	RATE (€)	AMOUNT(€)
1	Main Building-1/36-Furniture on two walls, furniture bodies thickness 18 mm laminated board, wood-veneer fronts, upper cupboards-glass fronts-lakomat, lower full veneered- classic sliding and opening. Blum accessories: drawers full extension with ballbearing quiet, hinges, veneered plinth with gasket, handles RE AO 07-0160-COO-G08. Chrome dish rack. Table top conglomerate HANEX 42 mm /Corian.	Main Building - Ground Floor	1/36	1		
2	Main Building-1/11-Furniture on one walls, furniture bodies thickness 18 mm laminated board, wood-veneer fronts, upper cupboards-glass fronts-lakomat, lower full veneered- classic sliding and opening. Blum accessories: drawers full extension with ballbearing quiet, hinges, veneered plinth with gasket, handles RE AO 07-0160-COO-G08. Chrome dish rack. Table top conglomerate HANEX 42 mm /Corian.	Main Building - Ground Floor	1/11	1		
3	Main Building-2/20-Furniture on one walls, furniture bodies thickness 18 mm laminated board, wood-veneer fronts, upper cupboards-glass fronts-lakomat, lower full veneered- classic sliding and opening. Blum accessories: drawers full extension with ballbearing quiet, hinges, veneered plinth with gasket, handles RE AO 07-0160-COO-G08. Chrome dish rack. Table top conglomerate HANEX 42 mm /Corian.	Main Building - Second Floor	2/20	1		
4	Main Building-2/27-Furniture on two walls, furniture bodies thickness 18 mm laminated board, wood-veneer fronts, upper cupboards-glass fronts-lakomat, lower full veneered- classic sliding and opening. Blum accessories: drawers full extension with ballbearing quiet, hinges, veneered plinth with gasket, handles RE AO 07-0160-COO-G08. Chrome dish rack. Table top conglomerate HANEX 42 mm /Corian.	Main Building - Second Floor	2/27	1		

RESIDENCES KITCHEN						
S.N.	DESCRIPTIONS	KITCHEN /PANTRY	ROOM NO.	QUANTITY	RATE (€)	AMOUNT(€)
1	First Secretary -1A/5, 1B/5 - Furniture on two walls, furniture bodies thickness 18 mm laminated board, wood-veneer fronts, upper cupboards-glass fronts-lakomat, lower full veneered- classic sliding and opening. Blum accessories: drawers full extension with ballbearing quiet, hinges, veneered plinth with gasket, handles RE AO 07-0160-COO-G08. Chrome dish rack. Table top conglomerate HANEX 42 mm /Corian.	First Secretary-Ground Floor	1A/5,1B/5	2		
2	Staff Residence-Furniture on three walls, furniture bodies thickness 18 mm laminated board, wood-veneer fronts, painted with matt lacquer Antracyt, upper cupboards-glass fronts-lakomat, lower full veneered- classic sliding and opening. Blum accessories: drawers full extension with ballbearing quiet, hinges, veneered plinth with gasket, handles RE AO 07-0160-COO-G08.Metal shelf corner and Chrome dish rack. Table top conglomerate HANEX 42 mm /Corian.	Staff-Residence-Ground Floor	1/2.3,1/1.5, 1/3.3	3		
3	Staff Residence-Furniture on three walls, furniture bodies thickness 18 mm laminated board, wood-veneer fronts, painted with matt lacquer Antracyt, upper cupboards-glass fronts-lakomat, lower full veneered- classic sliding and opening. Blum accessories: drawers full extension with ballbearing quiet, hinges, veneered plinth with gasket, handles RE AO 07-0160-COO-G08.Metal shelf corner and Chrome dish rack. Table top conglomerate HANEX 42 mm /Corian.	Staff-Residence-First Floor	1/3.3,1/4.3, 2/5.3,2/7.3	4		

RESIDENCES KITCHEN						
S.N.	DESCRIPTIONS	KITCHEN /PANTRY	ROOM NO.	QUANTITY	RATE (€)	AMOUNT(€)
4	Staff Residence-Furniture on three walls, furniture bodies thickness 18 mm laminated board, wood-veneer fronts, painted with matt lacquer Antracyt, upper cupboards-glass fronts-lakomat, lower full veneered- classic sliding and opening. Blum accessories: drawers full extension with ballbearing quiet, hinges, veneered plinth with gasket, handles RE AO 07-0160-COO-G08.Metal shelf corner and Chrome dish rack. Table top conglomerate HANEX 42 mm /Corian.	Staff-Residence-Second Floor	3/8.3,3/9.3	2		
5	Guard room-Furniture on two walls, furniture bodies thickness 18 mm laminated board, wood-veneer fronts, painted with matt lacquer Antracyt, upper cupboards-glass fronts-lakomat, lower full veneered- classic sliding and opening. Blum accessories: drawers full extension with ballbearing quiet, hinges, veneered plinth with gasket, handles RE AO 07-0160-COO-G08.Metal shelf corner and Chrome dish rack. Table top conglomerate HANEX 42 mm /Corian.	Guard room		2		

NOTE:
COOKING RANGE WITH GAS
BURNER & ELECTRIC OVEN/GRILL

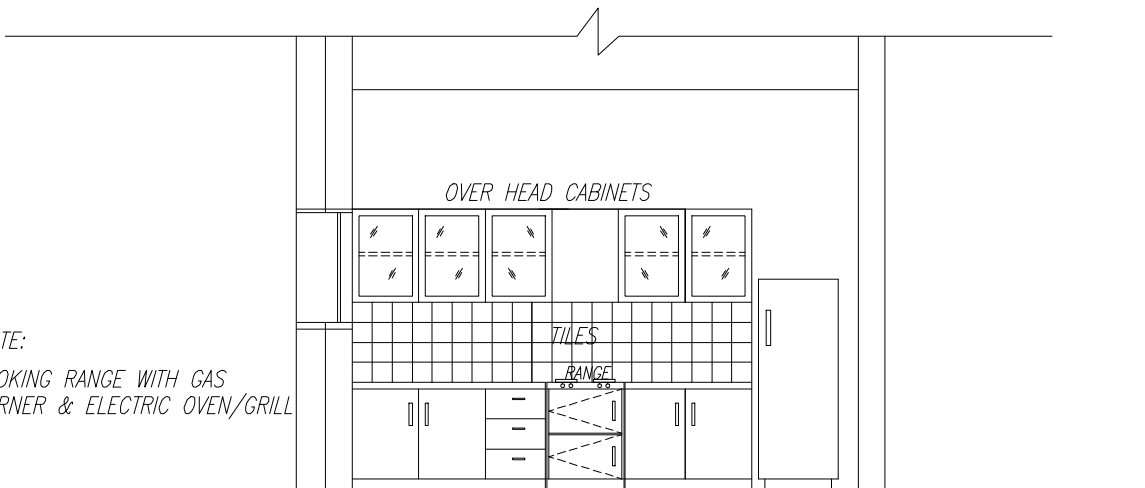

ELEVATION AT E-2-E-2

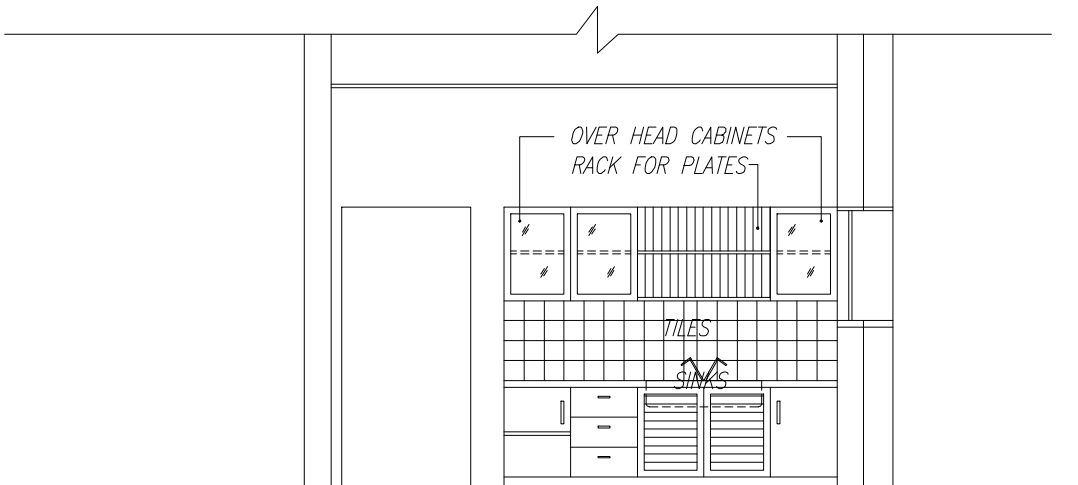

ELEVATION AT E-1-E-1

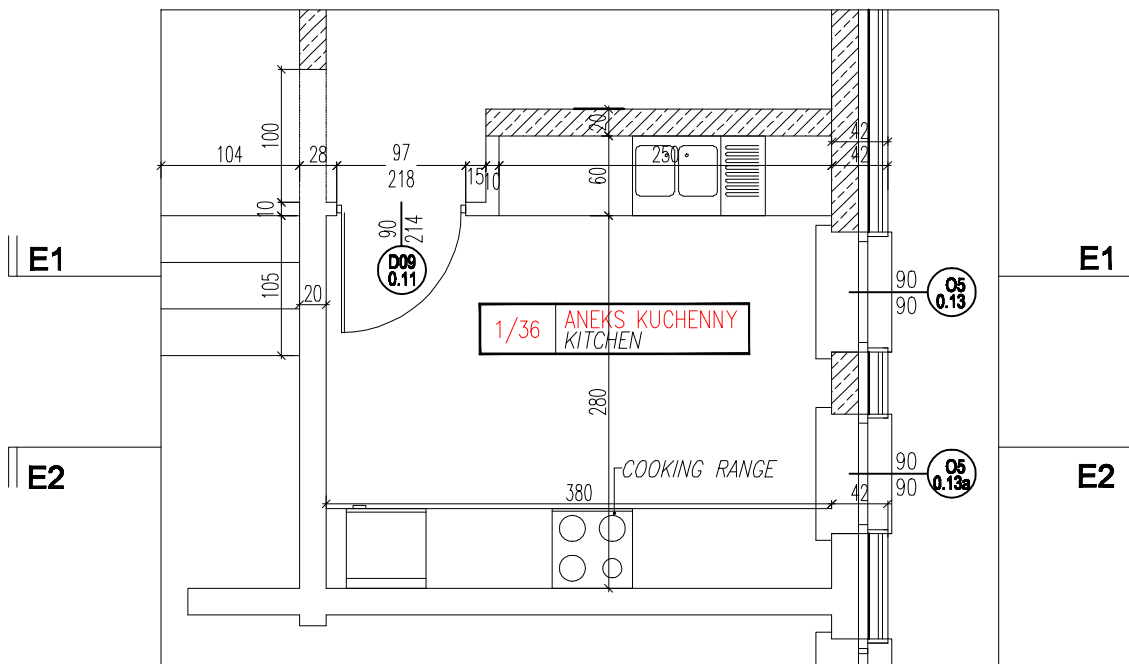

INDIAN EMBASSY, WARSAW

PRELIMINARY WORKING DRAWING

SACHDEV EGGLESTON ASSOCIATES
architects planners designers

NOTES

KEY PLAN

JOB NO

DATE

ISSUED BY

SHEET TITLE

DEALT

CHECKED

SCALE

KITCHEN MAIN BUILDING PLAN

DWG. NO

MAHAVIR

NTS

01

this drawing is the property of the architects and is not to be used or reproduced without their permission.

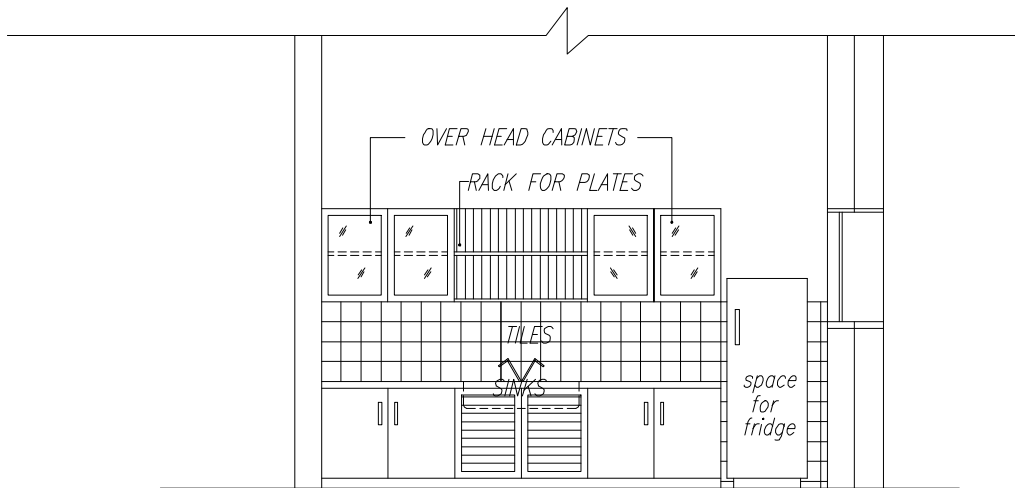

ELEVATION AT E-1-E-1

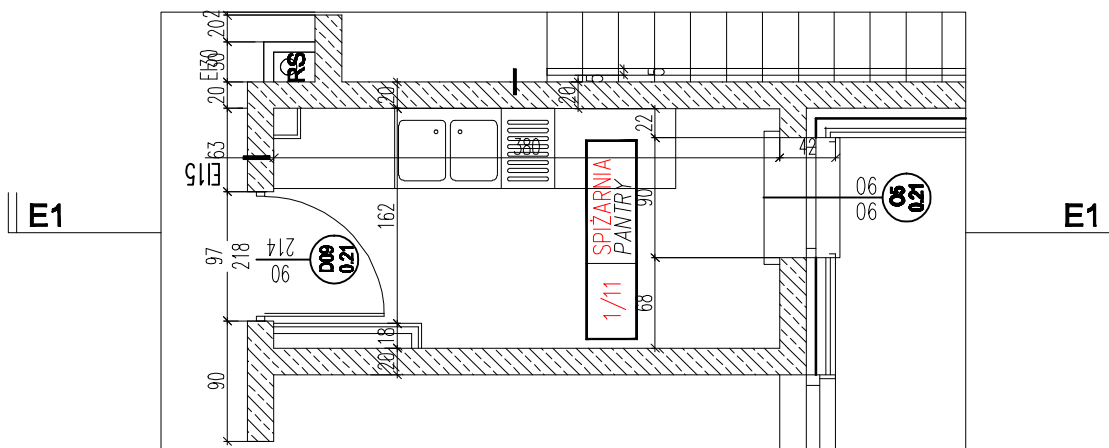

INDIAN EMBASSY, WARSAW	NOTES	KEY PLAN	JOB NO	DATE	ISSUED BY	SHEET TITLE	Dwg. NO
			DEALT MAHAVIR	NOV, DEC 2018	NTS	PANTRY-GROUND FLOOR MAIN BUILDING PLAN	
PRELIMINARY WORKING DRAWING							
SACHDEV EGGLESTON ASSOCIATES architects planners designers						this drawing is the property of the architects and is not to be used or reproduced without their permission.	

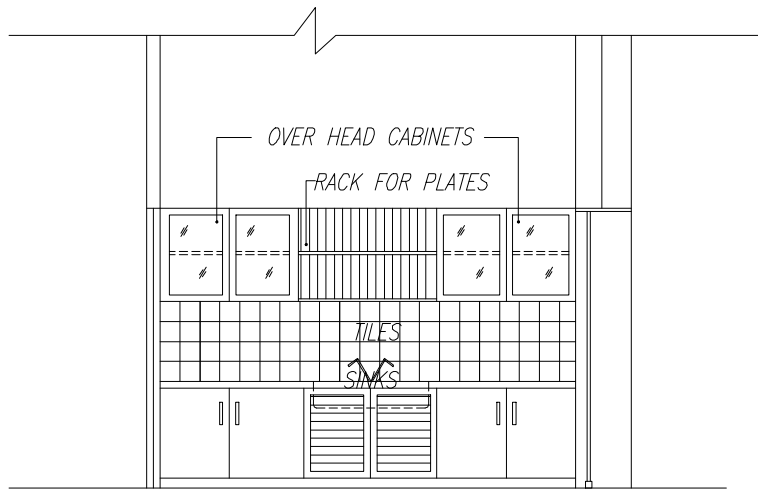

ELEVATION AT E-1-E-1

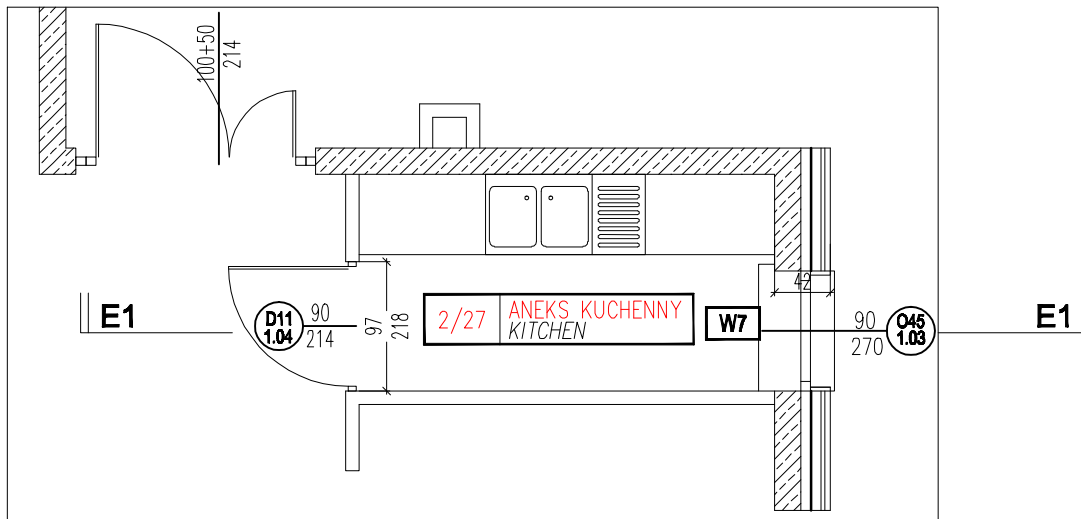

INDIAN EMBASSY, WARSAW	NOTES	KEY PLAN	JOB NO	DATE	ISSUED BY	SHEET TITLE	DRG. NO
				NOV_DEC 2018			
PRELIMINARY WORKING DRAWING			DEALT MANAVER	CHECKED	SCALE		
SACHDEV EGGLESTON ASSOCIATES architects planners designers						this drawing is the property of the architects and is not to be used or reproduced without their permission.	

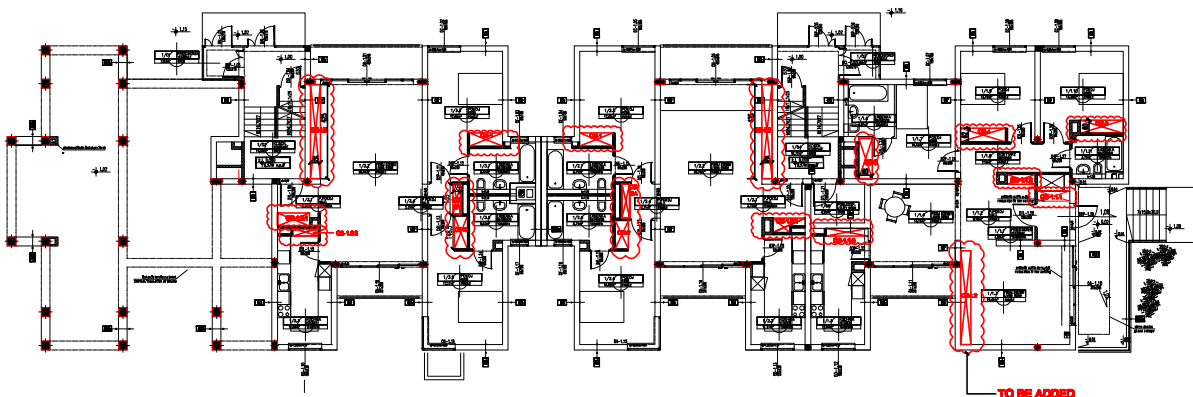

TO BE ADDED

GENERAL NOTES

1. All work shall be in accordance with the approved contract documents.
2. The contractor shall be responsible for obtaining all necessary permits.
3. All materials and workmanship shall conform to the approved specifications.
4. The contractor shall maintain access to all existing services.
5. All work shall be completed within the approved schedule.
6. The contractor shall be responsible for the protection of all existing work.
7. All work shall be inspected and approved by the appropriate authority.
8. The contractor shall be responsible for the disposal of all waste materials.
9. All work shall be completed in accordance with the approved drawings.
10. The contractor shall be responsible for the safety of all workers.

REVISIONS

NO.	DATE	DESCRIPTION
1	10/10/2023	ISSUED FOR PERMITTING
2	10/10/2023	ISSUED FOR PERMITTING
3	10/10/2023	ISSUED FOR PERMITTING

10/10/2023
 10/10/2023
 10/10/2023

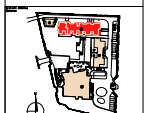

NO.	DATE	DESCRIPTION	BY	APP.
1	10/10/2023	ISSUED FOR PERMITTING		
2	10/10/2023	ISSUED FOR PERMITTING		
3	10/10/2023	ISSUED FOR PERMITTING		

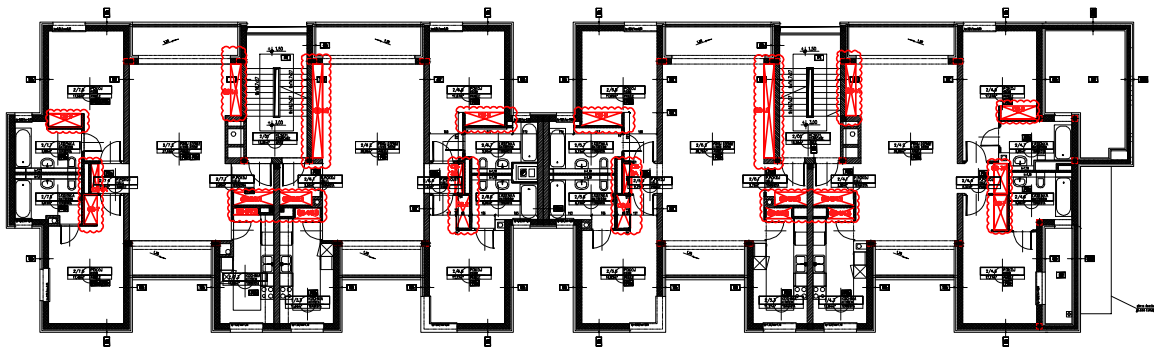

NOTES:

1. All work shall be in accordance with the approved contract documents.
2. All work shall be in accordance with the approved contract documents.
3. All work shall be in accordance with the approved contract documents.
4. All work shall be in accordance with the approved contract documents.
5. All work shall be in accordance with the approved contract documents.
6. All work shall be in accordance with the approved contract documents.
7. All work shall be in accordance with the approved contract documents.
8. All work shall be in accordance with the approved contract documents.
9. All work shall be in accordance with the approved contract documents.
10. All work shall be in accordance with the approved contract documents.

REVISIONS:

NO.	DESCRIPTION	DATE
1	AS SHOWN	11/11/2011
2	REVISION	11/11/2011
3	REVISION	11/11/2011
4	REVISION	11/11/2011
5	REVISION	11/11/2011
6	REVISION	11/11/2011
7	REVISION	11/11/2011
8	REVISION	11/11/2011
9	REVISION	11/11/2011
10	REVISION	11/11/2011

APPENDIX A:

NO.	DESCRIPTION	DATE
1	AS SHOWN	11/11/2011
2	REVISION	11/11/2011
3	REVISION	11/11/2011
4	REVISION	11/11/2011
5	REVISION	11/11/2011
6	REVISION	11/11/2011
7	REVISION	11/11/2011
8	REVISION	11/11/2011
9	REVISION	11/11/2011
10	REVISION	11/11/2011

APPENDIX B:

NO.	DESCRIPTION	DATE
1	AS SHOWN	11/11/2011
2	REVISION	11/11/2011
3	REVISION	11/11/2011
4	REVISION	11/11/2011
5	REVISION	11/11/2011
6	REVISION	11/11/2011
7	REVISION	11/11/2011
8	REVISION	11/11/2011
9	REVISION	11/11/2011
10	REVISION	11/11/2011

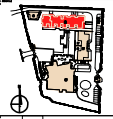

NO.	DESCRIPTION	DATE
1	AS SHOWN	11/11/2011
2	REVISION	11/11/2011
3	REVISION	11/11/2011
4	REVISION	11/11/2011
5	REVISION	11/11/2011
6	REVISION	11/11/2011
7	REVISION	11/11/2011
8	REVISION	11/11/2011
9	REVISION	11/11/2011
10	REVISION	11/11/2011

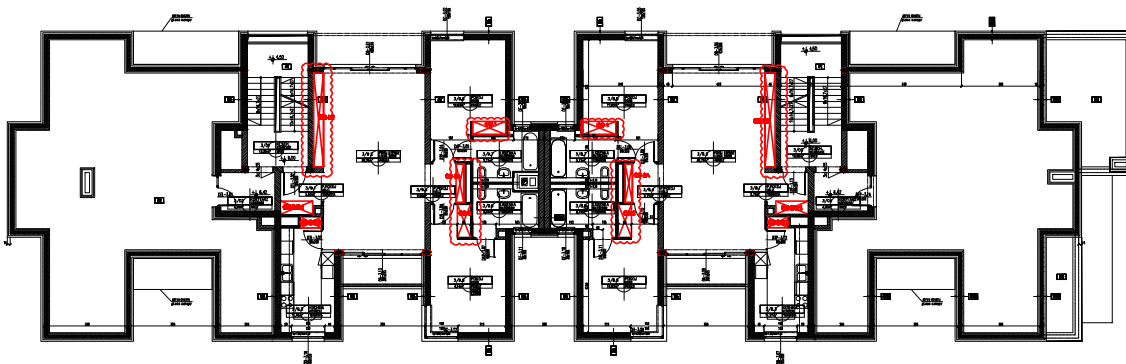

SECOND FLOOR PLAN

GENERAL NOTES

1. All work shall be in accordance with the latest edition of the Building Code of the City of Los Angeles.
2. All work shall be in accordance with the latest edition of the California Building Code.
3. All work shall be in accordance with the latest edition of the International Building Code.
4. All work shall be in accordance with the latest edition of the International Fire Code.
5. All work shall be in accordance with the latest edition of the International Mechanical Code.
6. All work shall be in accordance with the latest edition of the International Plumbing Code.
7. All work shall be in accordance with the latest edition of the International Electrical Code.
8. All work shall be in accordance with the latest edition of the International Fire and Safety Code.
9. All work shall be in accordance with the latest edition of the International Fire and Safety Code.
10. All work shall be in accordance with the latest edition of the International Fire and Safety Code.

REVISIONS

NO.	DESCRIPTION	DATE
1	REVISION	11-18-04
2	REVISION	11-18-04
3	REVISION	11-18-04
4	REVISION	11-18-04
5	REVISION	11-18-04
6	REVISION	11-18-04
7	REVISION	11-18-04
8	REVISION	11-18-04
9	REVISION	11-18-04
10	REVISION	11-18-04

PROJECT INFORMATION

PROJECT NO. 11-18-04
 SHEET NO. 11-18-04-01
 DATE 11-18-04
 DRAWN BY [Name]
 CHECKED BY [Name]
 APPROVED BY [Name]

LEGEND

- Red lines: Fire zone
- Black lines: Wall
- Grey lines: Door
- Blue lines: Stair
- Green lines: Elevation

INDEX

11-18-04-01 SECOND FLOOR PLAN
 11-18-04-02 FIRST FLOOR PLAN
 11-18-04-03 THIRD FLOOR PLAN
 11-18-04-04 FOURTH FLOOR PLAN
 11-18-04-05 MECHANICAL PLAN
 11-18-04-06 ELECTRICAL PLAN
 11-18-04-07 PLUMBING PLAN
 11-18-04-08 FIRE AND SAFETY PLAN

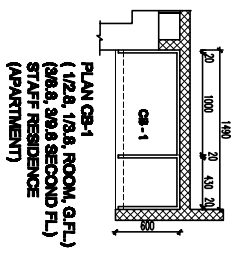
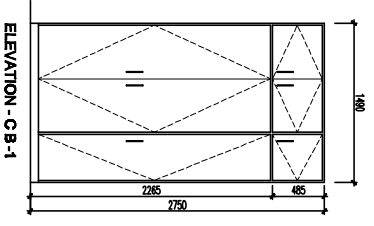
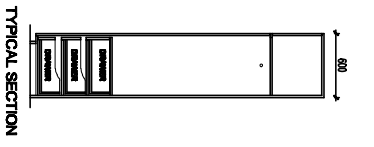
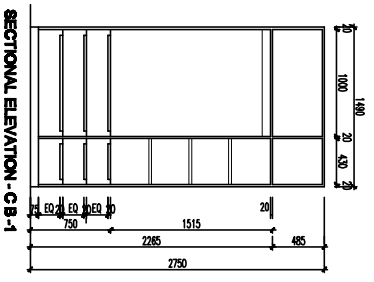

PLAN CB-1
(1/2A, 1/2B, ROOM, G.F.L.)
(3/8A, 3/2B SECOND F.L.)
STAFF RESIDENCE
(APARTMENT)

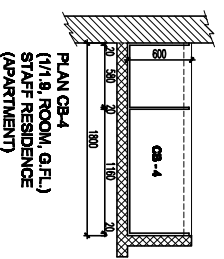
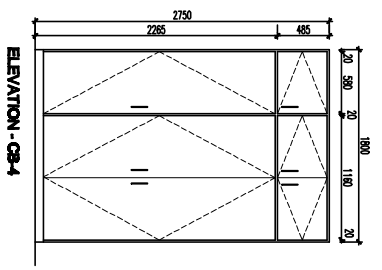
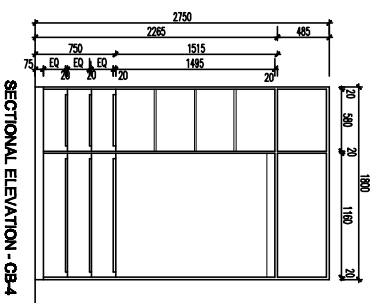

PLAN CB-4
(1/1A, ROOM, G.F.L.)
STAFF RESIDENCE
(APARTMENT)

INDIAN EMBASSY, WARSAW		UNIT	NO. OF UNITS	DATE	REVISION
STAFF RESIDENCE					
BACHDEV EGGLESTON ASSOCIATES		ARCHITECT	PROJECT	DATE	REVISION
INDIAN EMBASSY, WARSAW		STAFF RESIDENCE	CLIPBOARDS	DATE	REVISION
INDIAN EMBASSY, WARSAW		STAFF RESIDENCE	STAFF RES.	DATE	REVISION
INDIAN EMBASSY, WARSAW		STAFF RESIDENCE	STAFF RES.	DATE	REVISION

This drawing is the property of the architect and is not to be used or reproduced without their permission.

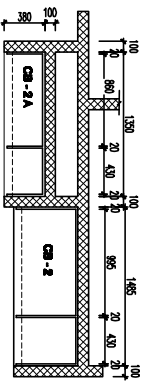
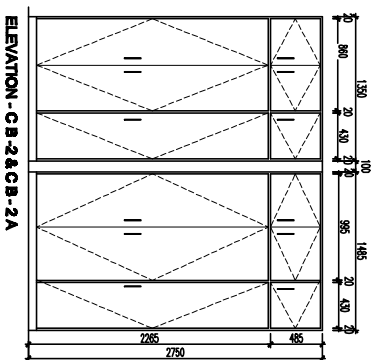
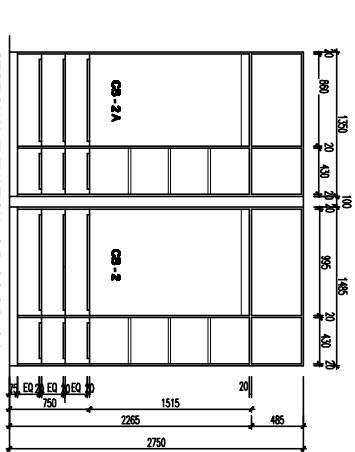

PLAN CB-2
 (CB-2A-1/2, 1/2, 1/4 G.F.L.), (CB-2A-1/6, 1/6, 1/8, 1/8 ROOM, F.F.L.)
 (CB-2A-9/8, 3/4, 3/4 S.F.L.)
 (CB-2-1/2, 1/2, 1/2 G.F.L.), (CB-2-2/5, 2/5, 2/5 F.F.L.)
 (CB-2- 3/8, 5, 3/8, 5)
STAFF RESIDENCE (APARTMENT)

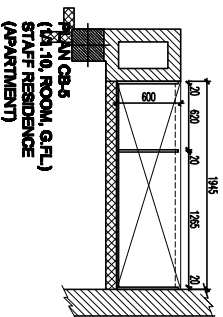
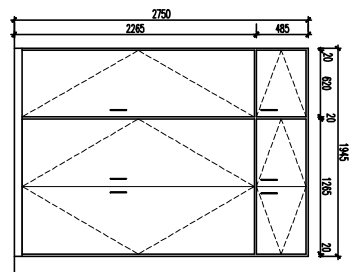
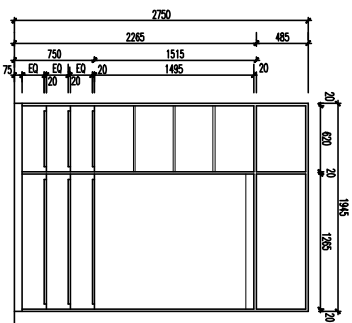

SECTIONAL CB-5
 (1/8, 1/8, ROOM, G.F.L.)
STAFF RESIDENCE
(APARTMENT)

INDIAN EMBASSY, WARSAW

STAFF RESIDENCE

BACHDEV EGGLESTON ASSOCIATES

DATE	REVISION	BY	CHK	APP

This drawing is the property of the architect and is not to be used or reproduced without their permission.

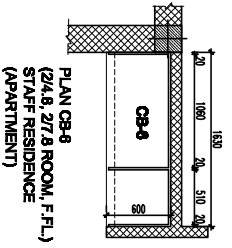
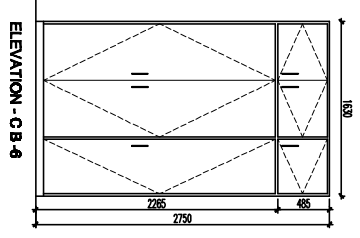
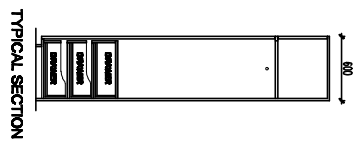
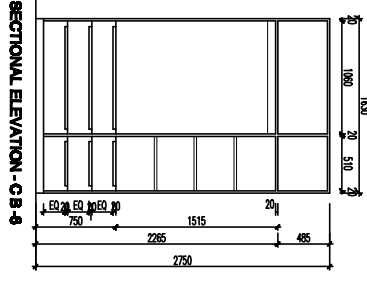
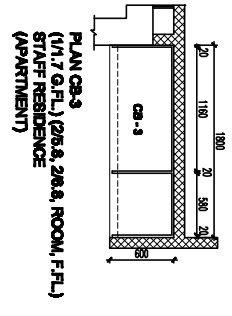
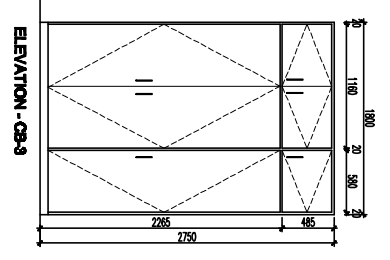
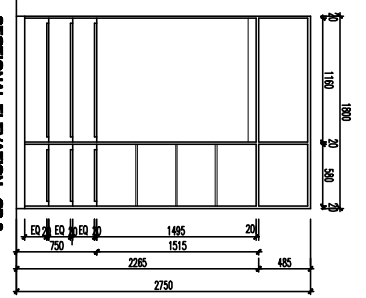

INDIAN EMBASSY, WARSAW		UNIT 1	AREA	DATE	DESIGNED BY	DATE	PROJECT
STAFF RESIDENCE					CLIPBOARDS		STAFF RES.
BACHDEV EGGLESTON ASSOCIATES							
architects interior designers							
<p style="font-size: small;">This drawing is the property of the architects and is not to be used or reproduced without their permission.</p>							

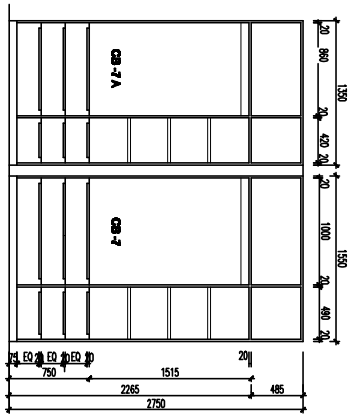

SECTIONAL ELEVATION - CB-7&CB-7

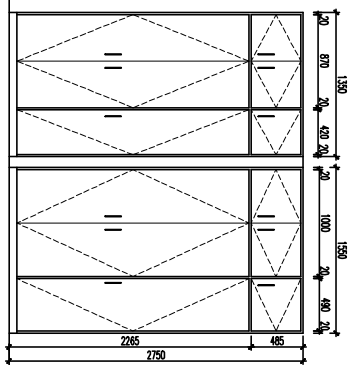

ELEVATION - CB-7&CB-7

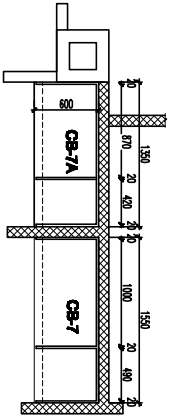

PLAN CB-7&CB-7
 (2/4.4, 2/4.5, 2/7.4, 2/7.5; ROOM, F.F.L.)
 STAFF RESIDENCE
 (APARTMENT)

INDIAN EMBASSY, WARSAW	NOHS	2021.01.01	DATE	ISSUED BY	PROJECT
STAFF RESIDENCE					
SACHDEV EQULESTON ASSOCIATES		2021.01.01	DATE	ISSUED BY	PROJECT
architect partners designers					
				CLIPBOARDS	1/24
				STAFF RES.	

The drawing is the property of the architect and is not to be used or reproduced without his/her permission.

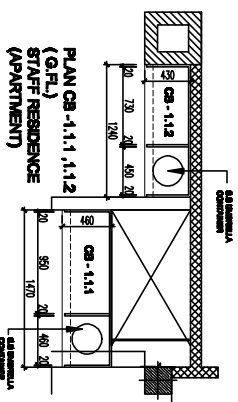
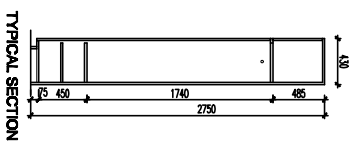
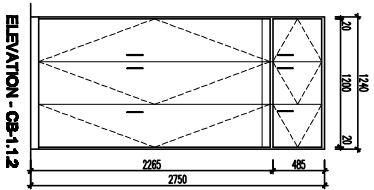
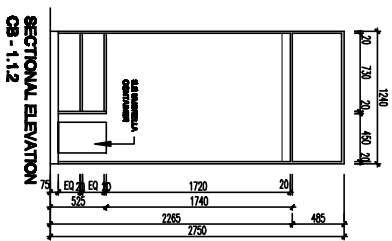
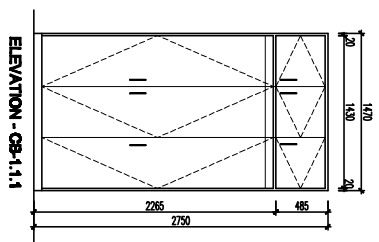
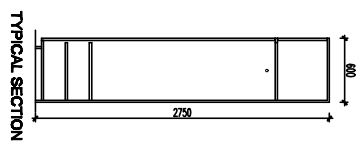
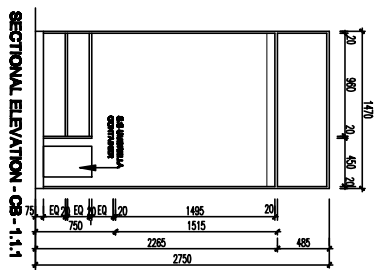

INDIAN EMBASSY, WARSAW
STAFF RESIDENCE

UNITS

AREA

NO.

DATE

REVISION

NO.

DATE

REVISION

NO.

DATE

REVISION

NO.

DATE

REVISION

NO.

DATE

REVISION

NO.

DATE

REVISION

NO.

DATE

ARCHITECTS: POJANNA, DUBINSKI

INDIAN EMBASSY, WARSAW

STAFF RESIDENCE

CLIPBOARDS

STAFF RES.

4-08

DATE

REVISION

NO.

DATE

REVISION

NO.

DATE

REVISION

NO.

DATE

REVISION

NO.

DATE

REVISION

NO.

DATE

This drawing is the property of the architect and is not to be used or reproduced without their permission.

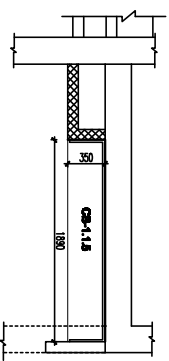
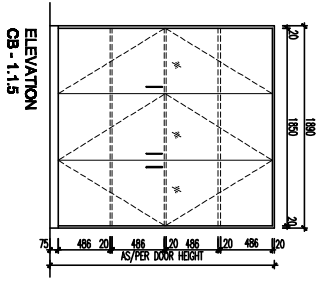
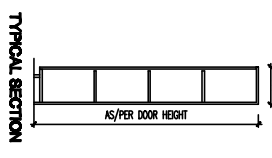
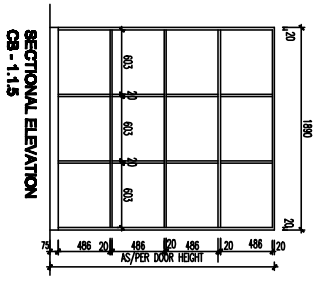
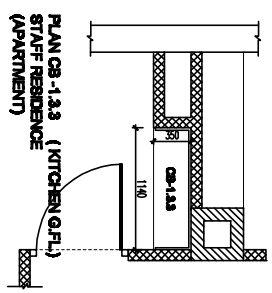
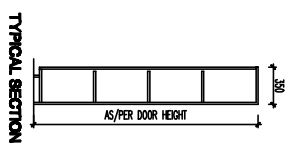
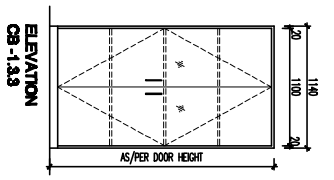
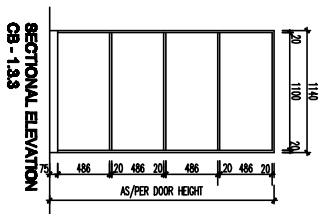

PLAN CB-1.1.5 (KITCHEN G.F.L.)
STAFF RESIDENCE
(APARTMENT)

INDIAN EMBASSY, WARSAW

STAFF RESIDENCE

BACHDEV EGGLESTON ASSOCIATES

architects interior designers

NO.	DATE	REVISION	BY	CHK.
1		ISSUED FOR CONSTRUCTION		
2		REVISION		
3		REVISION		
4		REVISION		
5		REVISION		

CLIPBOARDS
STAFF RES.

DATE: 10/08

All drawings are the property of the architect and to be used or reproduced only with their permission.

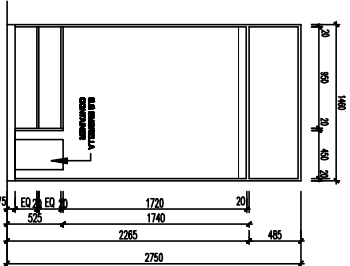

SECTIONAL ELEVATION - CB-121

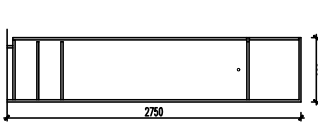

TYPICAL SECTION

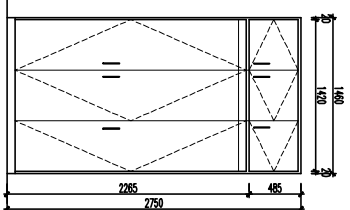

ELEVATION - CB-121

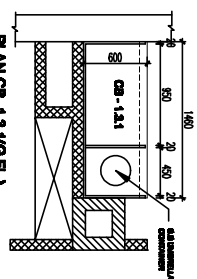

PLAN CB-121 (Q.F.L.)
 CB-20.1, CB-22.1, CB-26.1, 28.1,
 FIRST FL, SECOND FL,
 STAFF RESIDENCE
 (APARTMENT)

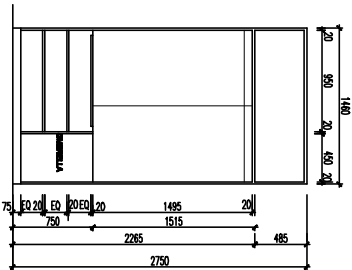

SECTIONAL ELEVATION - CB-121

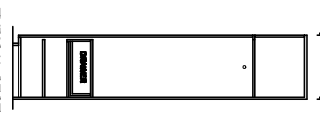

TYPICAL SECTION

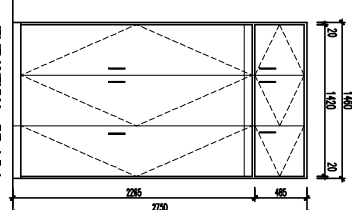

ELEVATION - CB-121

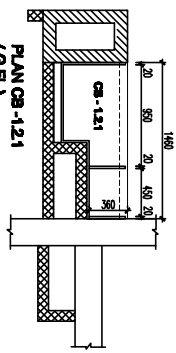

PLAN CB-121
 (Q.F.L.)
 STAFF RESIDENCE
 (APARTMENT)

INDIAN EMBASSY, WARSAW		UNIT		SECTIONAL ELEVATION		DATE		REVISION BY		SCALE	
STAFF RESIDENCE								CLIPBOARDS		DATE	
BACHDEV EGGLESTON ASSOCIATES		ARCHITECTS		POLSKA 10		01.10.2017		STAFF RES.		A-07	
The drawings in this document are the property of the architect and are to be used or reproduced only with their permission.											

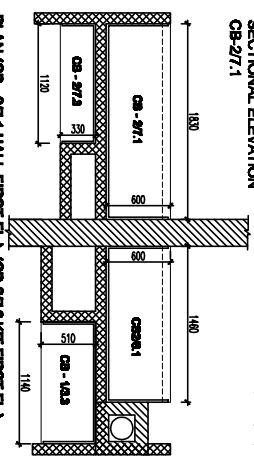
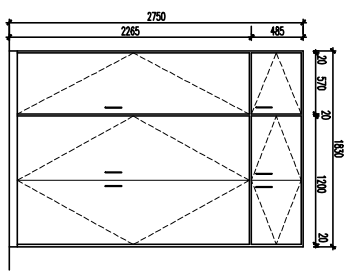
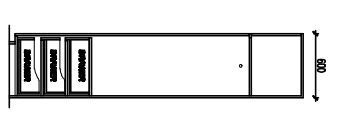
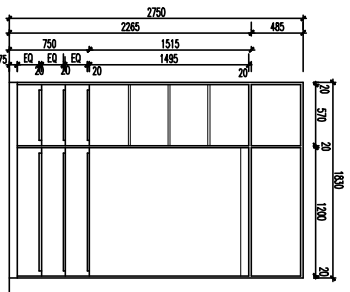
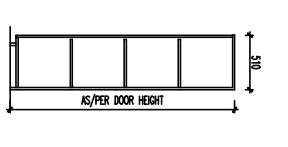
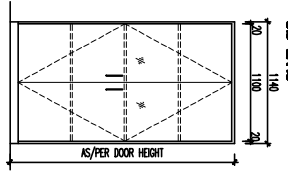
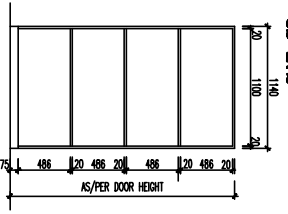
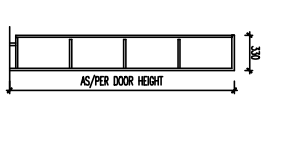
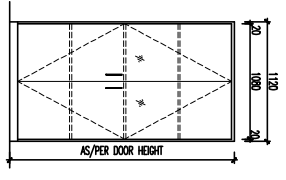
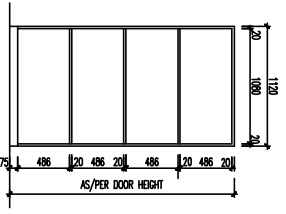

PLAN (CB-27/1 HALL FIRST FL.) (CB-18/3 KIT. FIRST FL.)
 STAFF RESIDENCE (APARTMENT)
 STAFF RESIDENCE (APARTMENT)

INDIAN EMBASSY, WARSAW		UNITS		APARTMENT		APARTMENT		APARTMENT	
STAFF RESIDENCE		UNITS		APARTMENT		APARTMENT		APARTMENT	
BACHDEV EGGLESTON ASSOCIATES		ARCHITECTS		PARTNERS		DESIGNERS		DATE	
INDIAN EMBASSY, WARSAW		UNITS		APARTMENT		APARTMENT		APARTMENT	
STAFF RESIDENCE		UNITS		APARTMENT		APARTMENT		APARTMENT	
BACHDEV EGGLESTON ASSOCIATES		ARCHITECTS		PARTNERS		DESIGNERS		DATE	
INDIAN EMBASSY, WARSAW		UNITS		APARTMENT		APARTMENT		APARTMENT	
STAFF RESIDENCE		UNITS		APARTMENT		APARTMENT		APARTMENT	
BACHDEV EGGLESTON ASSOCIATES		ARCHITECTS		PARTNERS		DESIGNERS		DATE	

THIS DRAWING IS THE PROPERTY OF THE ARCHITECTS AND IS NOT TO BE LOANED OR REPRODUCED WITH OUT THEIR PERMISSION.

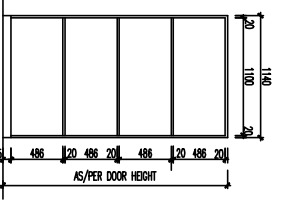

SECTIONAL ELEVATION
CB - 26.3, CB-14.3, FIRST FL.

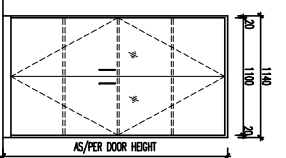

ELEVATION
CB - 26.3, CB-14.3, FIRST FL.

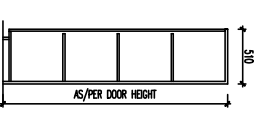

TYPICAL SECTION

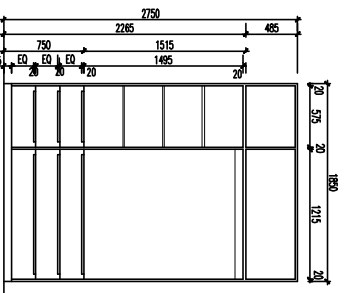

SECTIONAL ELEVATION
CB-24.1



TYPICAL SECTION

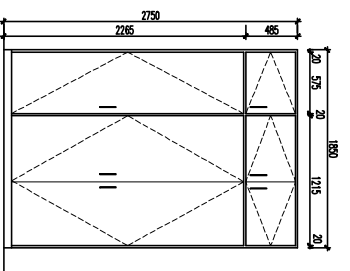

ELEVATION - CB-24.1

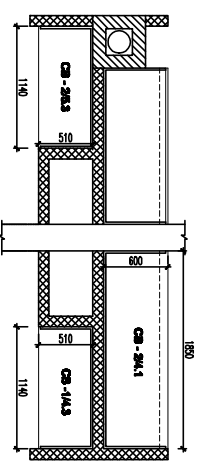

PLAN CB-26.3 KIT, C.B-24.1 HALL, (CB-14.3 KIT X FIRST FL.)
STAFF RESIDENCE
(APARTMENT)

INDIAN EMBASSY, WARSAW		UNIT	NO. OF UNITS	DATE	REVISION
STAFF RESIDENCE					
BACHDEV EGGLESTON ASSOCIATES		ARCHITECT	PROJECT	DATE	REVISION
architects partners designers					
<p>The drawings is the property of the architect and is not to be used or reproduced without their permission.</p>		SCALE	DATE	REVISION	DATE
		1:50		CLIPBOARDS STAFF RES.	1.00

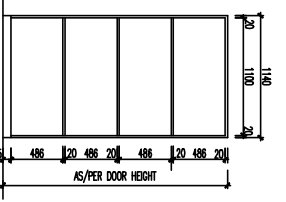

SECTIONAL ELEVATION
CB - 26.3, CB-14.3, FIRST FL.

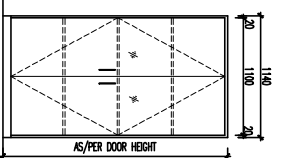

ELEVATION
CB - 26.3, CB-14.3, FIRST FL.

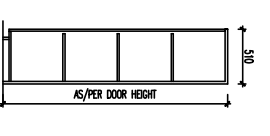

TYPICAL SECTION

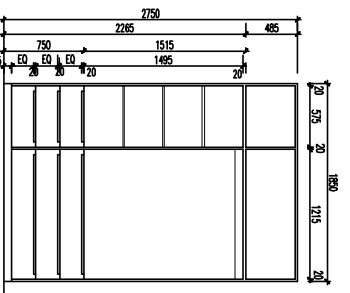

SECTIONAL ELEVATION
CB-24.1



TYPICAL SECTION

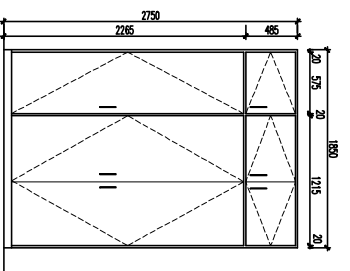

ELEVATION - CB-24.1

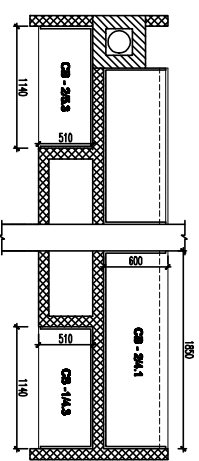

PLAN CB-26.3 KIT, C.B-24.1 HALL, (CB-14.3 KIT X FIRST FL.)
STAFF RESIDENCE
(APARTMENT)

INDIAN EMBASSY, WARSAW		UNIT	NO. OF UNITS	DATE	REVISION
STAFF RESIDENCE					
BACHDEV EGGLESTON ASSOCIATES		ARCHITECT	PROJECT	DATE	REVISION
architects partners designers					
INDIAN EMBASSY, WARSAW		STAFF RESIDENCE	CLIPBOARDS	DATE	REVISION
<p>This drawing is the property of the architect and is not to be used or reproduced without their permission.</p>					

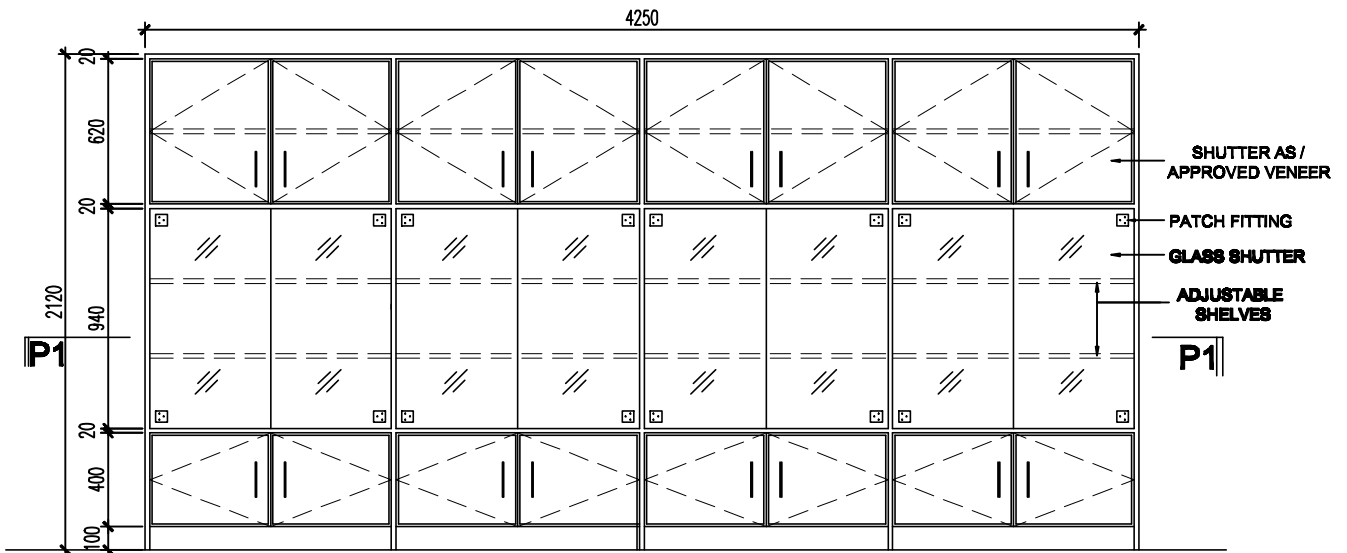

ELEVATION AT E1-E1

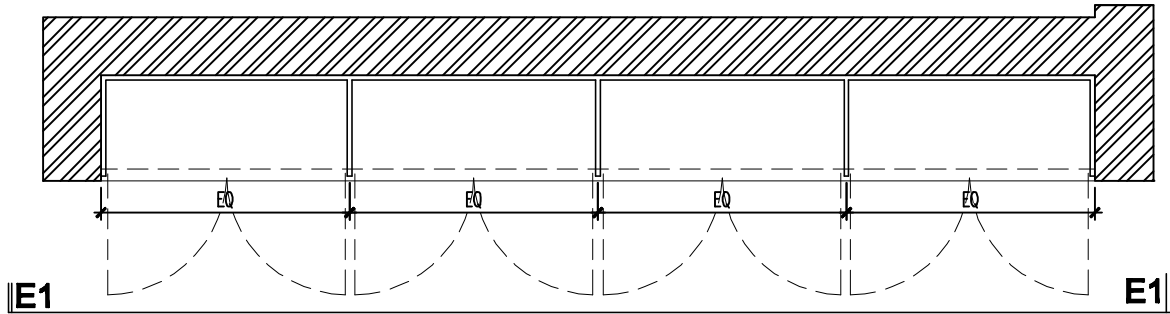

PLAN AT P1-P1 (CB-L2)

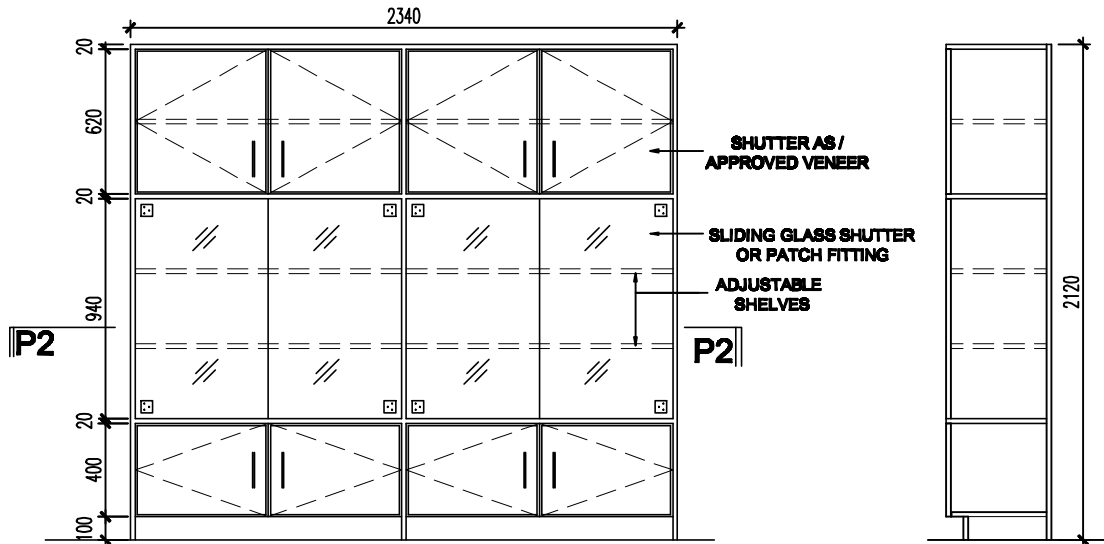

ELEVATION AT E1-E1

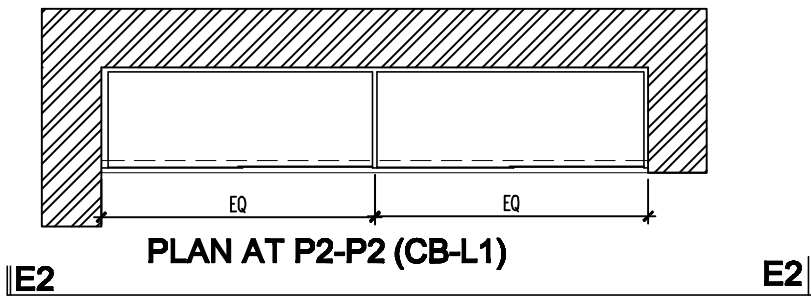

PLAN AT P2-P2 (CB-L1)

INDIAN EMBASSY, WARSAW

STAFF RESIDENCE

SACHDEV EGGLESTON ASSOCIATES
architects planners designers

NOTES

KEY PLAN

JOB NO

DATE

DESIGNED BY SHEET TITLE

DEALT

MANWR

CHECKED

SCALE

1:20

**CUPBOARDS
LIVING ROOM**

DWG. NO

this drawing is the property of the architects and is not to be used or reproduced without their permission.

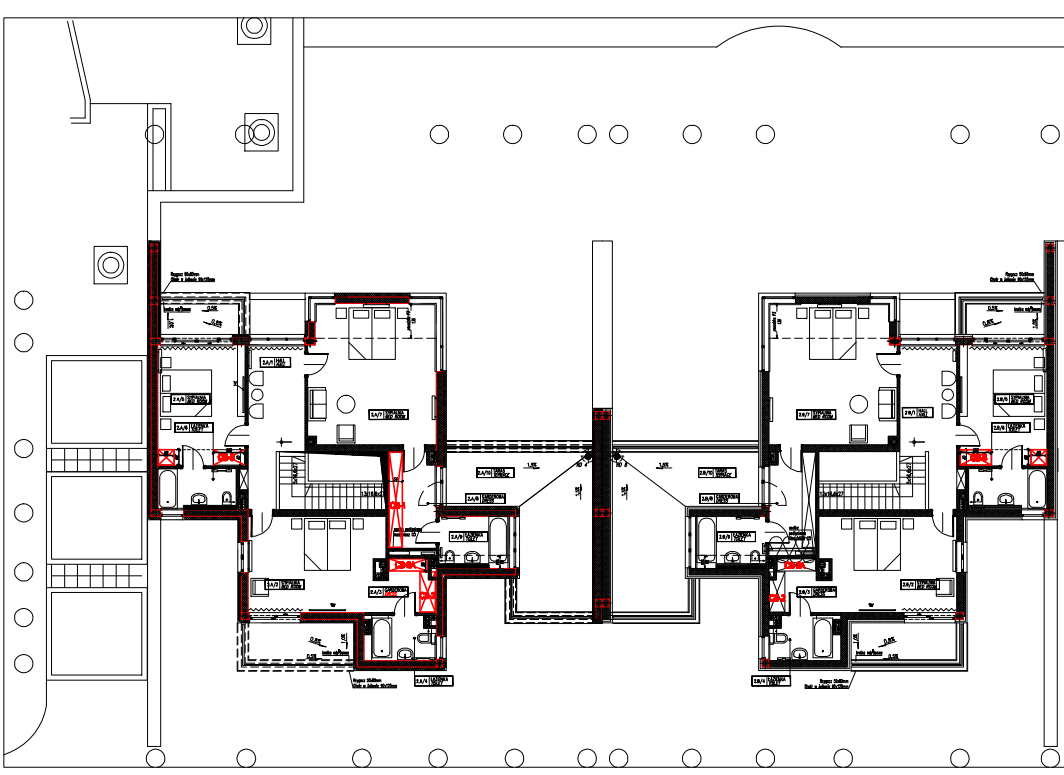

NO.	DESCRIPTION	QTY	UNIT	PRICE	TOTAL	REMARKS
1.01	CONCRETE SLAB	100	M ²	12.00	1200.00	
1.02	REINFORCEMENT	5000	KG	0.80	4000.00	
1.03	BREASTING	1000	M ²	3.50	3500.00	
1.04	FORMWORK	2000	M ²	1.50	3000.00	
1.05	BRICKWORK	15000	M ³	1.00	15000.00	
1.06	PLASTER	20000	M ²	0.50	10000.00	
1.07	PAINTING	3000	M ²	0.40	1200.00	
1.08	ROOFING	1000	M ²	1.50	1500.00	
1.09	MECHANICAL	500	M ²	2.50	1250.00	
1.10	ELECTRICAL	300	M ²	2.00	600.00	

NOTES:

- All dimensions are in meters unless otherwise specified.
- Structural steel members are to be welded unless otherwise indicated.
- Reinforcement is to be 12mm diameter unless otherwise specified.
- Concrete is to be of the design strength as shown on the drawings.
- Brickwork is to be of the design strength as shown on the drawings.
- Plaster is to be of the design strength as shown on the drawings.
- Painting is to be of the design strength as shown on the drawings.
- Roofing is to be of the design strength as shown on the drawings.
- Mechanical and electrical works are to be as shown on the drawings.
- All works are to be done in accordance with the relevant standards and specifications.
- Material and workmanship are to be of the highest quality.
- The contractor is to be responsible for the coordination and supervision of the works.
- The contractor is to be responsible for the safety of the works.
- The contractor is to be responsible for the completion of the works.
- The contractor is to be responsible for the maintenance of the works.
- The contractor is to be responsible for the disposal of the waste.
- The contractor is to be responsible for the clean-up of the site.
- The contractor is to be responsible for the security of the site.
- The contractor is to be responsible for the access of the site.
- The contractor is to be responsible for the parking of the vehicles.
- The contractor is to be responsible for the use of the site.
- The contractor is to be responsible for the protection of the site.
- The contractor is to be responsible for the preservation of the site.
- The contractor is to be responsible for the restoration of the site.

LEGEND:

- 1 - Structural Steel Members
- 2 - Reinforcement
- 3 - Brickwork
- 4 - Plaster
- 5 - Painting
- 6 - Roofing
- 7 - Mechanical
- 8 - Electrical

GENERAL INFORMATION:

PROJECT NAME	
CLIENT NAME	
DATE	
SCALE	
DRAWN BY	
CHECKED BY	
APPROVED BY	

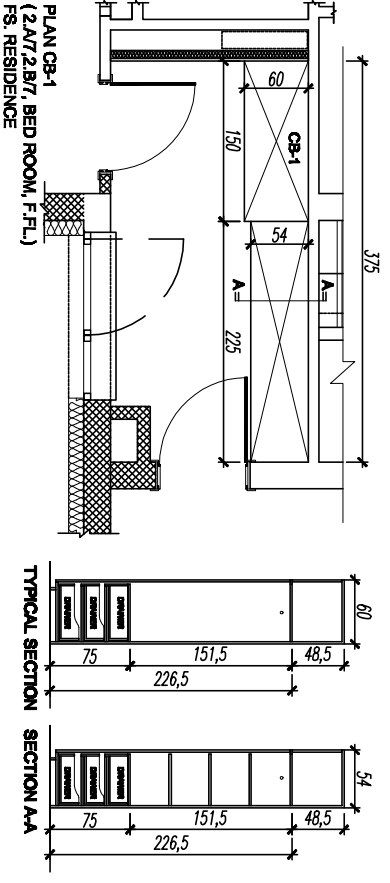
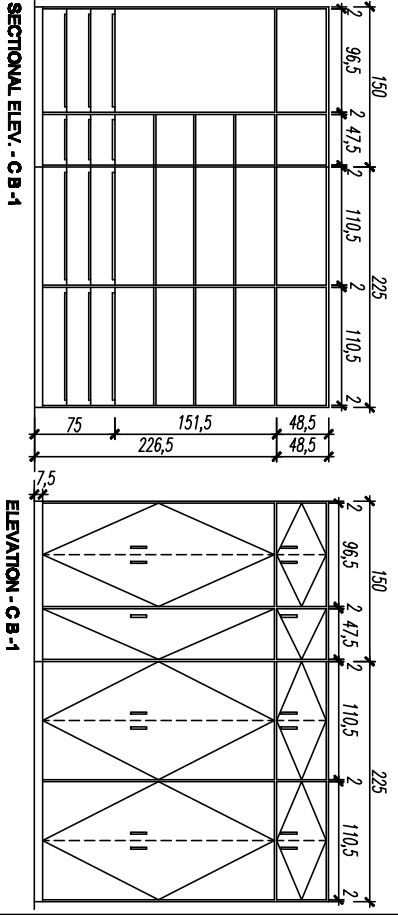
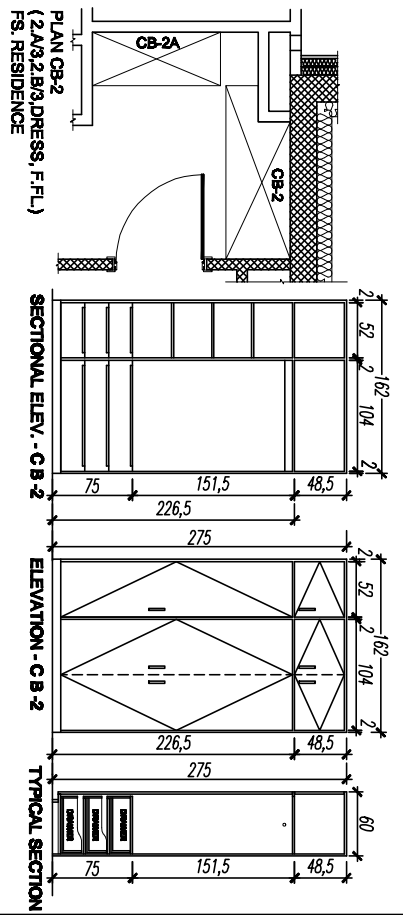

INDIAN EMBASSY, WARSAW		NOTES		ART. NAME		DATE		DESIGNED BY		DRAWN BY		CHECKED BY		SCALE		SHEET NO.		TOTAL SHEETS	
FIRST SECRETARY RESIDENCE								CLIPBOARDS		FS, RES.								A-1	
<p>SACHDEV EQUILESTON ASSOCIATES architects partners designers</p> <p>Any drawing is the property of the architect and is not to be used or reproduced without their permission.</p>																			

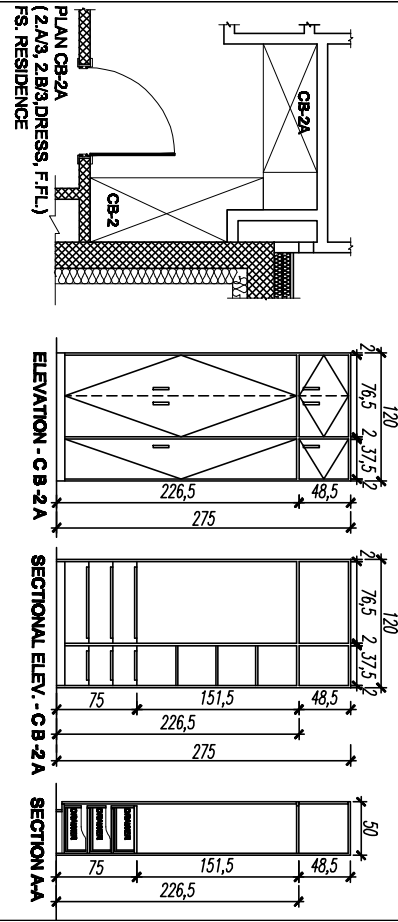
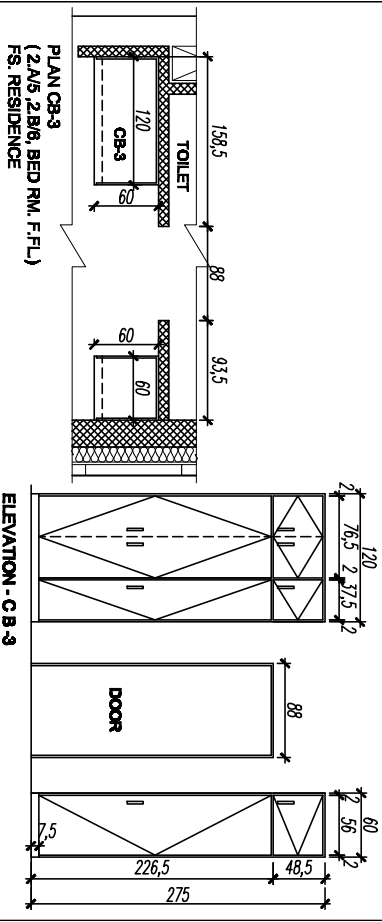
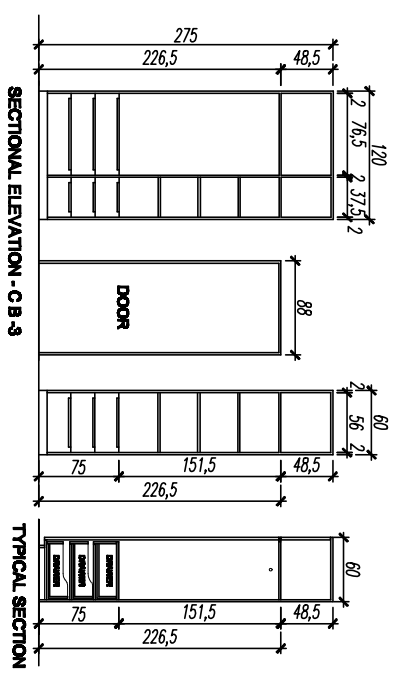

INDIAN EMBASSY, WARSAW		NOTES		ART/DRAW		DATE		CUPBOARDS		SHEET NO	
FIRST SECRETARY RESIDENCE								F.S. RES.		A/02	
SACHDEV EQULESTON ASSOCIATES		architects partners designers		INC.		198					

All drawings in this property of the architect and in not to be used or reproduced without their permission.

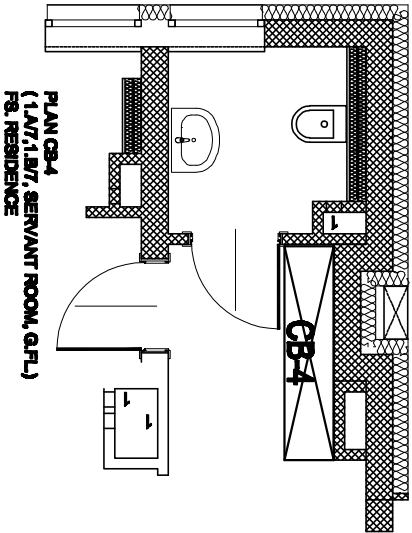
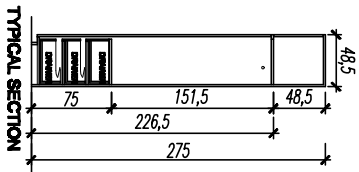
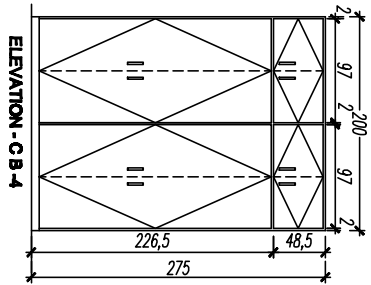
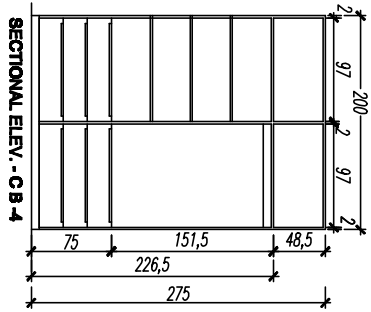

PLAN CB-4
(1A/1.B/1. SERVANT ROOM, G.F.L.)
FS. RESIDENCE

INDIAN EMBASSY, WARSAW		NOTES	ART. PLAN	DATE	DESIGNER/ARCHITECT	SCALE	FILE NO.
FIRST SECRETARY RESIDENCE					CUPBOARDS		101.107
SACHDEV EQULESTON ASSOCIATES			PK.	199	FS. RES.		A-3
architects partners designers		This drawing is the property of the architect and is not to be used or reproduced without their permission.					

F5

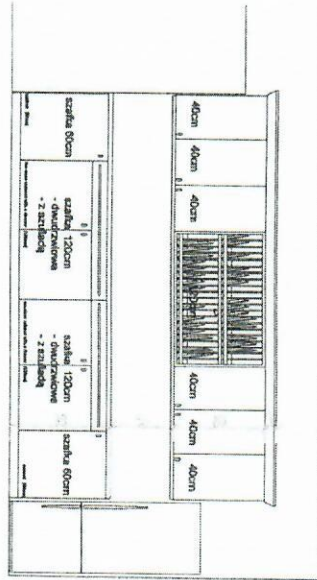
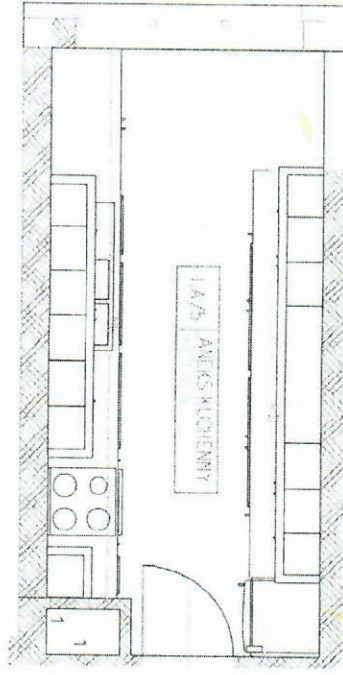

WZGL

WZGL 01

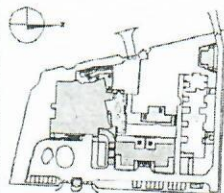
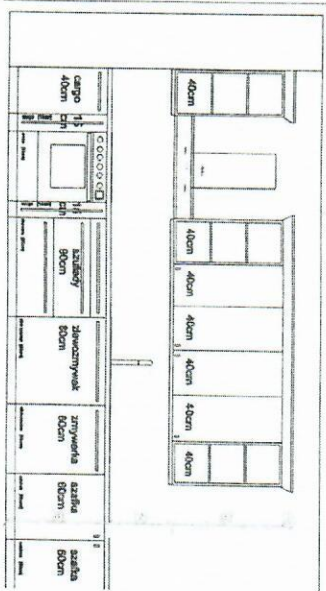
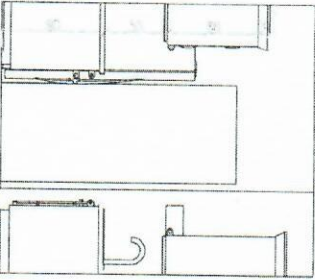
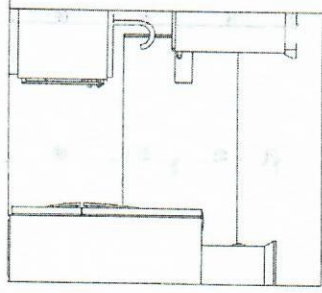



Pracownia Projektowa

 ANULKA STYBIL-KIEME

Projekt: ANULKA STYBIL-KIEME

 Adres: ...

 Data: ...

Atache

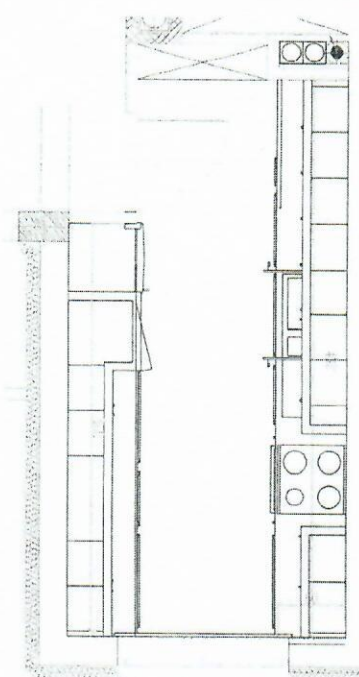

PLAN 01

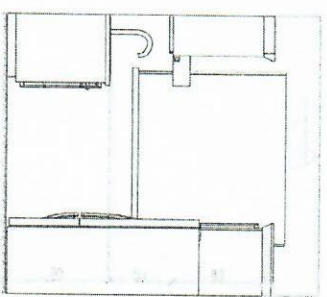

PLAN 02

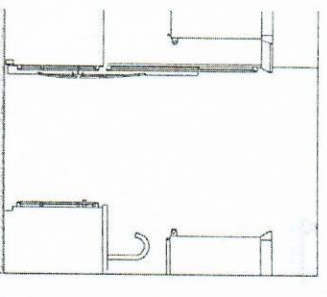

PLAN 04

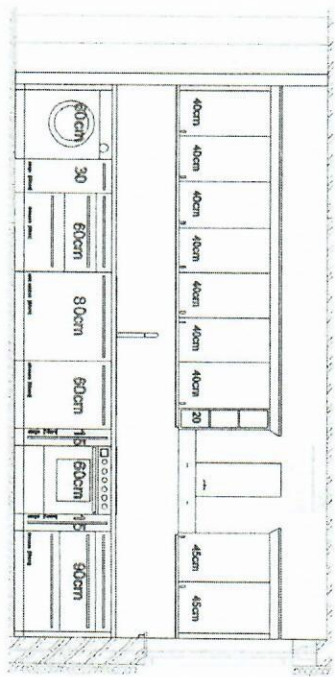

PLAN 03

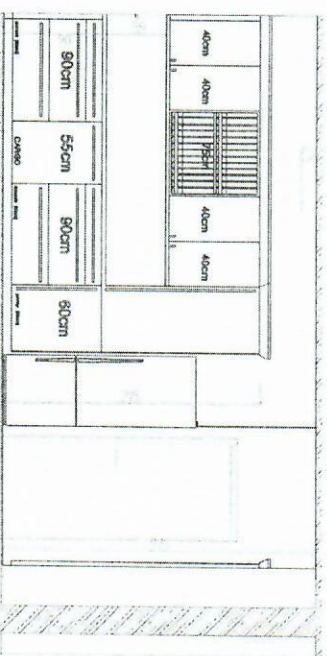

PLAN 05

Architectural information block containing:
- A site plan showing the building's location within a plot.
- The name of the architectural firm: **AMMANI & PARTNERS**
- The name of the architect: **AMMANI, PARTNERS**
- The name of the project: **AMMANI & PARTNERS**
- The address: **100, 101, 102, 103, 104, 105, 106, 107, 108, 109, 110, 111, 112, 113, 114, 115, 116, 117, 118, 119, 120, 121, 122, 123, 124, 125, 126, 127, 128, 129, 130, 131, 132, 133, 134, 135, 136, 137, 138, 139, 140, 141, 142, 143, 144, 145, 146, 147, 148, 149, 150, 151, 152, 153, 154, 155, 156, 157, 158, 159, 160, 161, 162, 163, 164, 165, 166, 167, 168, 169, 170, 171, 172, 173, 174, 175, 176, 177, 178, 179, 180, 181, 182, 183, 184, 185, 186, 187, 188, 189, 190, 191, 192, 193, 194, 195, 196, 197, 198, 199, 200, 201, 202, 203, 204, 205, 206, 207, 208, 209, 210, 211, 212, 213, 214, 215, 216, 217, 218, 219, 220, 221, 222, 223, 224, 225, 226, 227, 228, 229, 230, 231, 232, 233, 234, 235, 236, 237, 238, 239, 240, 241, 242, 243, 244, 245, 246, 247, 248, 249, 250, 251, 252, 253, 254, 255, 256, 257, 258, 259, 260, 261, 262, 263, 264, 265, 266, 267, 268, 269, 270, 271, 272, 273, 274, 275, 276, 277, 278, 279, 280, 281, 282, 283, 284, 285, 286, 287, 288, 289, 290, 291, 292, 293, 294, 295, 296, 297, 298, 299, 300, 301, 302, 303, 304, 305, 306, 307, 308, 309, 310, 311, 312, 313, 314, 315, 316, 317, 318, 319, 320, 321, 322, 323, 324, 325, 326, 327, 328, 329, 330, 331, 332, 333, 334, 335, 336, 337, 338, 339, 340, 341, 342, 343, 344, 345, 346, 347, 348, 349, 350, 351, 352, 353, 354, 355, 356, 357, 358, 359, 360, 361, 362, 363, 364, 365, 366, 367, 368, 369, 370, 371, 372, 373, 374, 375, 376, 377, 378, 379, 380, 381, 382, 383, 384, 385, 386, 387, 388, 389, 390, 391, 392, 393, 394, 395, 396, 397, 398, 399, 400, 401, 402, 403, 404, 405, 406, 407, 408, 409, 410, 411, 412, 413, 414, 415, 416, 417, 418, 419, 420, 421, 422, 423, 424, 425, 426, 427, 428, 429, 430, 431, 432, 433, 434, 435, 436, 437, 438, 439, 440, 441, 442, 443, 444, 445, 446, 447, 448, 449, 450, 451, 452, 453, 454, 455, 456, 457, 458, 459, 460, 461, 462, 463, 464, 465, 466, 467, 468, 469, 470, 471, 472, 473, 474, 475, 476, 477, 478, 479, 480, 481, 482, 483, 484, 485, 486, 487, 488, 489, 490, 491, 492, 493, 494, 495, 496, 497, 498, 499, 500, 501, 502, 503, 504, 505, 506, 507, 508, 509, 510, 511, 512, 513, 514, 515, 516, 517, 518, 519, 520, 521, 522, 523, 524, 525, 526, 527, 528, 529, 530, 531, 532, 533, 534, 535, 536, 537, 538, 539, 540, 541, 542, 543, 544, 545, 546, 547, 548, 549, 550, 551, 552, 553, 554, 555, 556, 557, 558, 559, 560, 561, 562, 563, 564, 565, 566, 567, 568, 569, 570, 571, 572, 573, 574, 575, 576, 577, 578, 579, 580, 581, 582, 583, 584, 585, 586, 587, 588, 589, 590, 591, 592, 593, 594, 595, 596, 597, 598, 599, 600, 601, 602, 603, 604, 605, 606, 607, 608, 609, 610, 611, 612, 613, 614, 615, 616, 617, 618, 619, 620, 621, 622, 623, 624, 625, 626, 627, 628, 629, 630, 631, 632, 633, 634, 635, 636, 637, 638, 639, 640, 641, 642, 643, 644, 645, 646, 647, 648, 649, 650, 651, 652, 653, 654, 655, 656, 657, 658, 659, 660, 661, 662, 663, 664, 665, 666, 667, 668, 669, 670, 671, 672, 673, 674, 675, 676, 677, 678, 679, 680, 681, 682, 683, 684, 685, 686, 687, 688, 689, 690, 691, 692, 693, 694, 695, 696, 697, 698, 699, 700, 701, 702, 703, 704, 705, 706, 707, 708, 709, 710, 711, 712, 713, 714, 715, 716, 717, 718, 719, 720, 721, 722, 723, 724, 725, 726, 727, 728, 729, 730, 731, 732, 733, 734, 735, 736, 737, 738, 739, 740, 741, 742, 743, 744, 745, 746, 747, 748, 749, 750, 751, 752, 753, 754, 755, 756, 757, 758, 759, 760, 761, 762, 763, 764, 765, 766, 767, 768, 769, 770, 771, 772, 773, 774, 775, 776, 777, 778, 779, 780, 781, 782, 783, 784, 785, 786, 787, 788, 789, 790, 791, 792, 793, 794, 795, 796, 797, 798, 799, 800, 801, 802, 803, 804, 805, 806, 807, 808, 809, 810, 811, 812, 813, 814, 815, 816, 817, 818, 819, 820, 821, 822, 823, 824, 825, 826, 827, 828, 829, 830, 831, 832, 833, 834, 835, 836, 837, 838, 839, 840, 841, 842, 843, 844, 845, 846, 847, 848, 849, 850, 851, 852, 853, 854, 855, 856, 857, 858, 859, 860, 861, 862, 863, 864, 865, 866, 867, 868, 869, 870, 871, 872, 873, 874, 875, 876, 877, 878, 879, 880, 881, 882, 883, 884, 885, 886, 887, 888, 889, 890, 891, 892, 893, 894, 895, 896, 897, 898, 899, 900, 901, 902, 903, 904, 905, 906, 907, 908, 909, 910, 911, 912, 913, 914, 915, 916, 917, 918, 919, 920, 921, 922, 923, 924, 925, 926, 927, 928, 929, 930, 931, 932, 933, 934, 935, 936, 937, 938, 939, 940, 941, 942, 943, 944, 945, 946, 947, 948, 949, 950, 951, 952, 953, 954, 955, 956, 957, 958, 959, 960, 961, 962, 963, 964, 965, 966, 967, 968, 969, 970, 971, 972, 973, 974, 975, 976, 977, 978, 979, 980, 981, 982, 983, 984, 985, 986, 987, 988, 989, 990, 991, 992, 993, 994, 995, 996, 997, 998, 999, 1000.**

Shotb

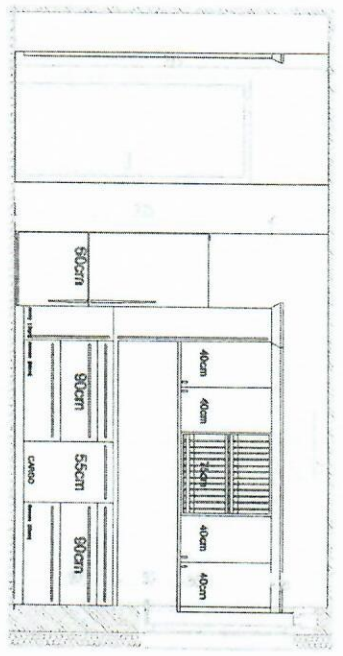
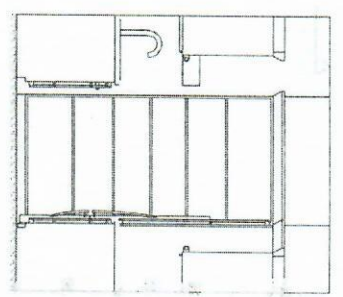
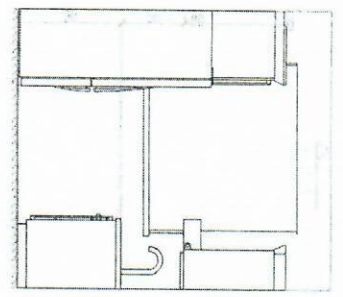
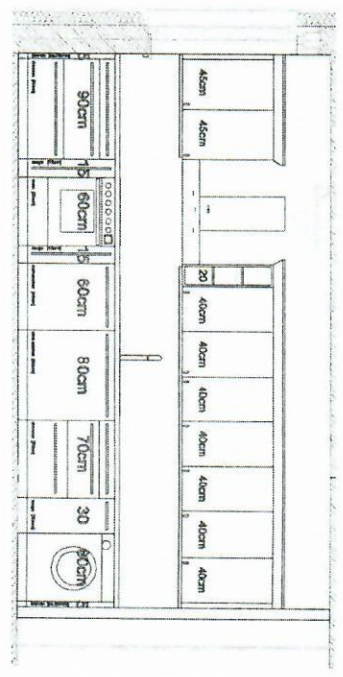
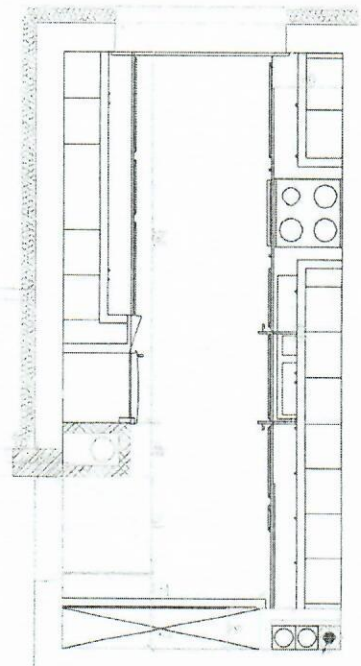

WIDOK 02

WIDOK 04

WIDOK 03

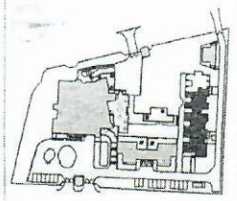

Architectural drawing details and notes, including a scale bar and technical specifications.

TO ROOM

TO ROOM

TO ROOM

TO ROOM

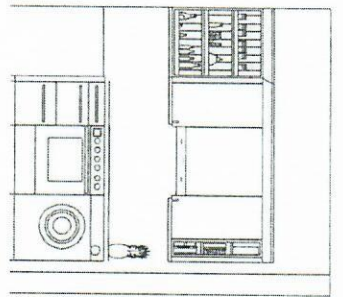
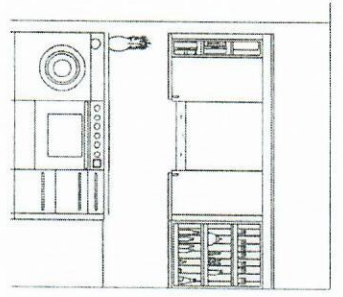
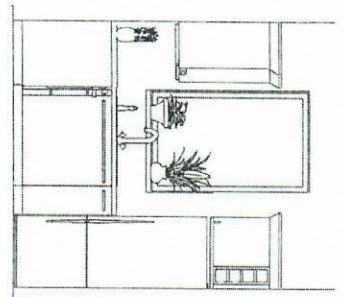
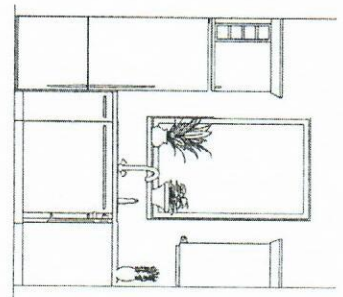

1/20

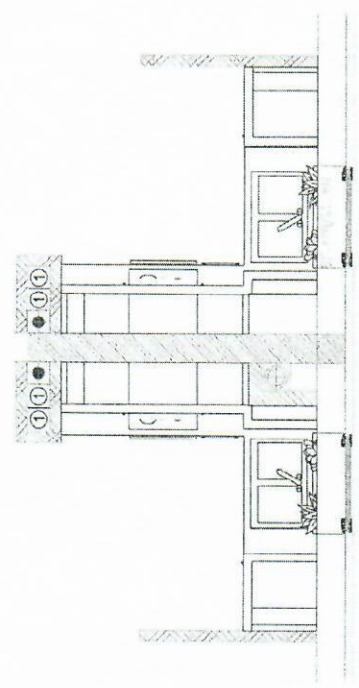

Security

PROJECT: [illegible]
 DRAWING NO.: [illegible]
 DATE: [illegible]
 SCALE: [illegible]
 SHEET NO.: [illegible]

ARCHITECT: [illegible]
 ENGINEER: [illegible]
 CONTRACTOR: [illegible]



सत्यमेव जयते

**THE GOVERNMENT OF INDIA
MINISTRY OF EXTERNAL AFFAIRS**

Fixed Furniture and Kitchen Cabinetry Works for Apartments and Chancery at the
New Indian Embassy at Warsaw
WARSAW, UL. MYSLLWIECKA/SZWOLEZEROW/KAWALERII

PART – II FINANCIAL BID

Prime Consultants :

**Sachdev Eggleston Associates
G-33, First Floor, Kalka Ji
New Delhi 110 019, India**

INDEX

NAME OF WORK : **Fixed Furniture and Kitchen cabinetry for Apartments and Chancery at the New Indian Embassy at Warsaw.**

LOCATION : The New Indian Embassy at Warsaw **WARSAW, UL. MYSLWIECKA/SZWOLEZEROW/KAWALERII**

	PAGES
1. FINANCIAL BID LETTER – ANNEXURE 6	03
2. PRICED SCHEDULE OF QUANTITIES (BOQ)	04-12

FINANCIAL BID LETTER

To

HEAD OF CHANCERY

Sir,

We declare:

That we are equipped with the infrastructure/expertise and other facilities required for carrying out the works “Fixed Furniture and Kitchen cabinetry for Apartments and Chancery at the New Indian Embassy at WARSAW, UL. MYSLLEWIECKA/SZWOLEZEROW/KAWALERII as per the requirements of the contract.

We do hereby undertake, that, In the event of acceptance of our bid, for the Fixed Furniture and Kitchen Cabinetry for Apartments and Chancery at WARSAW, UL. MYSLLEWIECKA/SZWOLEZEROW/KAWALERII shall be made as stipulated in the work order and the tender terms and conditions to the Bid. Our Tender Offer Price for the above Works all complete as per the requirements of the Contract is Euro _____ (_____ only).

We enclose herewith the complete Financial Bid as required by you. We have carefully read and understood the terms and conditions of the tender and the conditions of the contract applicable to the tender and we do hereby undertake the said works the Fixed Furniture and Kitchen Cabinetry for Apartments and Chancery at the New Indian Embassy at WARSAW, UL. MYSLLEWIECKA/SZWOLEZEROW/KAWALERII as per these terms and conditions.

All prices mentioned in our proposal are in accordance with the terms and condition specified in the bidding document and extant statutes/rules etc.

All the prices and other terms and conditions of this proposal are valid for a period of 180 calendar days from the opening of the bids.

We do hereby confirm that our bid prices are all inclusive.

1. Certified that we are: a sole proprietorship firm and the person signing the tender is the sole proprietor / constituted attorney of the sole proprietor,

Or a partnership firm, and the person signing the tender is the firm and he has authority to refer to arbitration disputes concerning the business of the partnership by virtue of the partnership agreement/by virtue of general power of attorney,

Or a company and the person signing the tender is the constituted attorney. (NOTE: Delete whatever is not applicable. All corrections/deletions should invariably be duly attested by the person authorized to sign the tender document.)

2. We do hereby undertake, that, until a formal contract is prepared and executed, this bid, together with your written acceptance thereof, the tender document and placement of letter of intent awarding the contract, shall constitute a binding contract between us.

Dated: Signature of authorized representative

- Name of Agency :
Full Address :
Company Seal :
Detail of enclosures :

FIXED FURNITRES BOQ FOR INDIAN EMBASSY WARSAW

MAIN BUILDING KITCHEN/PANTRY

S.N.	DESCRIPTIONS	KITCHEN /PANTRY	ROOM NO.	QUANTITY	RATE (€)	AMOUNT(€)
1	Main Building-1/36-Furniture on two walls, furniture bodies thickness 18 mm laminated board, wood-veneer fronts, upper cupboards-glass fronts-lakomat, lower full veneered- classic sliding and opening. Blum accessories: drawers full extension with ballbearing quiet, hinges, veneered plinth with gasket, handles RE AO 07-0160-COO-G08. Chrome dish rack. Table top conglomerate HANEX 42 mm /Corian.	Main Building - Ground Floor	1/36	1		
2	Main Building-1/11-Furniture on one walls, furniture bodies thickness 18 mm laminated board, wood-veneer fronts, upper cupboards-glass fronts-lakomat, lower full veneered- classic sliding and opening. Blum accessories: drawers full extension with ballbearing quiet, hinges, veneered plinth with gasket, handles RE AO 07-0160-COO-G08. Chrome dish rack. Table top conglomerate HANEX 42 mm /Corian.	Main Building - Ground Floor	1/11	1		
3	Main Building-2/20-Furniture on one walls, furniture bodies thickness 18 mm laminated board, wood-veneer fronts, upper cupboards-glass fronts-lakomat, lower full veneered- classic sliding and opening. Blum accessories: drawers full extension with ballbearing quiet, hinges, veneered plinth with gasket, handles RE AO 07-0160-COO-G08. Chrome dish rack. Table top conglomerate HANEX 42 mm /Corian.	Main Building - Second Floor	2/20	1		
4	Main Building-2/27-Furniture on two walls, furniture bodies thickness 18 mm laminated board, wood-veneer fronts, upper cupboards-glass fronts-lakomat, lower full veneered- classic sliding and opening. Blum accessories: drawers full extension with ballbearing quiet, hinges, veneered plinth with gasket, handles RE AO 07-0160-COO-G08. Chrome dish rack. Table top conglomerate HANEX 42 mm /Corian.	Main Building - Second Floor	2/27	1		

RESIDENCES KITCHEN						
S.N.	DESCRIPTIONS	KITCHEN /PANTRY	ROOM NO.	QUANTITY	RATE (€)	AMOUNT(€)
1	First Secretary -1A/5, 1B/5 - Furniture on two walls, furniture bodies thickness 18 mm laminated board, wood-veneer fronts, upper cupboards-glass fronts-lakomat, lower full veneered- classic sliding and opening. Blum accessories: drawers full extension with ballbearing quiet, hinges, veneered plinth with gasket, handles RE AO 07-0160-COO-G08. Chrome dish rack. Table top conglomerate HANEX 42 mm /Corian.	First Secretary-Ground Floor	1A/5,1B/5	2		
2	Staff Residence-Furniture on three walls, furniture bodies thickness 18 mm laminated board, wood-veneer fronts, painted with matt lacquer Antracyt, upper cupboards-glass fronts-lakomat, lower full veneered- classic sliding and opening. Blum accessories: drawers full extension with ballbearing quiet, hinges, veneered plinth with gasket, handles RE AO 07-0160-COO-G08.Metal shelf corner and Chrome dish rack. Table top conglomerate HANEX 42 mm /Corian.	Staff-Residence-Ground Floor	1/2.3,1/1.5, 1/3.3	3		
3	Staff Residence-Furniture on three walls, furniture bodies thickness 18 mm laminated board, wood-veneer fronts, painted with matt lacquer Antracyt, upper cupboards-glass fronts-lakomat, lower full veneered- classic sliding and opening. Blum accessories: drawers full extension with ballbearing quiet, hinges, veneered plinth with gasket, handles RE AO 07-0160-COO-G08.Metal shelf corner and Chrome dish rack. Table top conglomerate HANEX 42 mm /Corian.	Staff-Residence-First Floor	1/3.3,1/4.3, 2/5.3,2/7.3	4		

RESIDENCES KITCHEN						
S.N.	DESCRIPTIONS	KITCHEN /PANTRY	ROOM NO.	QUANTITY	RATE (€)	AMOUNT(€)
4	Staff Residence-Furniture on three walls, furniture bodies thickness 18 mm laminated board, wood-veneer fronts, painted with matt lacquer Antracyt, upper cupboards-glass fronts-lakomat, lower full veneered- classic sliding and opening. Blum accessories: drawers full extension with ballbearing quiet, hinges, veneered plinth with gasket, handles RE AO 07-0160-COO-G08.Metal shelf corner and Chrome dish rack. Table top conglomerate HANEX 42 mm /Corian.	Staff-Residence-Second Floor	3/8.3,3/9.3	2		
5	Guard room-Furniture on two walls, furniture bodies thickness 18 mm laminated board, wood-veneer fronts, painted with matt lacquer Antracyt, upper cupboards-glass fronts-lakomat, lower full veneered- classic sliding and opening. Blum accessories: drawers full extension with ballbearing quiet, hinges, veneered plinth with gasket, handles RE AO 07-0160-COO-G08.Metal shelf corner and Chrome dish rack. Table top conglomerate HANEX 42 mm /Corian.	Guard room		2		

FIXED FURNITURE BOQ FOR INDIAN EMBASSY WARSAW

FIRST SECRETARY RESIDENCE CUPBOARDS

S.N.	DESCRIPTIONS	CB'S NAMES	FLOOR	ROOM-NO	SIZE			QUANTITY	AREA	RATE(€)	AMOUNT(€)
					WIDTH	DEPTH	HEIGHT		SQM		
1	CB-1- Wardrobe, furniture board laminated body, 18 mm MDF fronts 19 mm thick opaque matt lacquered drawers with full extension ballbearing quiet, internal hinges Blum clips, metal handles, satin, brakes doors, baseboards painted.	CB-1	F.F.	2A/7, 2B/7	3.75	0.6	2.75	2	20.625		
2	CB-2- Wardrobe, furniture board laminated body, 18 mm MDF fronts 19 mm thick opaque matt lacquered drawers with full extension ballbearing quiet, internal hinges Blum clips, metal handles, satin, brakes doors, baseboards painted.	CB-2	F.F.	2A/3, 2B/3	1.62	0.3	2.1	2	6.804		
3	CB-2A- Wardrobe, furniture board laminated body, 18 mm MDF fronts 19 mm thick opaque matt lacquered drawers with full extension ballbearing quiet, internal hinges Blum clips, metal handles, satin, brakes doors, baseboards painted.	CB-2A	F.F.	2A/3, 2B/3	1.55	0.5	2.75	2	8.525		
4	CB-3- Wardrobe, furniture board laminated body,, 18 mm MDF fronts 19 mm thick opaque matt lacquered drawers with full extension ballbearing quiet, internal hinges Blum clips, metal handles, satin, brakes doors, baseboards painted.	CB-3	F.F.	2A/5, 2B/5	1.8	0.6	2.75	2	9.9		
5	CB-4- Wardrobe, furniture board laminated body,, 18 mm MDF fronts 19 mm thick opaque matt lacquered drawers with full extension ballbearing quiet, internal hinges Blum clips, metal handles, satin, brakes doors, baseboards painted.	CB-4	G.F.	1.A/7, 1.B/7	2.0	0.485	2.75	2	11		
Total front face area of F.S Cupboards									56.854		

STAFF RESIDENCE CUPBOARDS

S.N.	DESCRIPTIONS	CB'S NAMES	FLOOR	ROOM-NO	SIZE			QUANTITY	AREA	RATE(€)	AMOUNT(€)
					WIDTH	DEPTH	HEIGHT		SQM		
1	CB-1- Wardrobe, furniture board laminated body, 18 mm MDF fronts 19 mm thick opaque matt lacquered drawers with full extension ballbearing quiet, internal hinges Blum clips, metal handles, satin, brakes doors, baseboards painted.	CB-1	G.F.	1/2.8 ,1/3.8	1.49	0.6	2.75	2	8.195		
			S.F.	3/8.8, 3/ 9.8	1.49	0.6	2.75	2	8.195		
2	CB-2- Wardrobe, furniture board laminated body, 18 mm MDF fronts 19 mm thick opaque matt lacquered drawers with full extension ballbearing quiet, internal hinges Blum clips, metal handles, satin, brakes doors, baseboards painted.	CB-2	G.F.	1/2.5 ,1/3.5	1.485	0.6	2.75	2	8.1675		
			F.F.	2/5.5, 2/6.53	1.485	0.6	2.75	2	8.1675		
			S.F.	8.5, 3/ 9.5	1.485	0.6	2.75	2	8.1675		
3	CB-2A- Wardrobe, furniture board laminated body, 18 mm MDF fronts 19 mm thick opaque matt lacquered drawers with full extension ballbearing quiet, internal hinges Blum clips, metal handles, satin, brakes doors, baseboards painted.	CB-2A	G.F.	1/2.4 ,1/3.4	1.35	0.38	2.75	2	7.425		
			F.F.	2/5.4, 2/6.4	1.35	0.38	2.75	2	7.425		
			S.F.	3/8.4, 3/ 9.4	1.35	0.38	2.75	2	7.425		
4	CB-3- Wardrobe, furniture board laminated body, 18 mm MDF fronts 19 mm thick opaque matt lacquered drawers with full extension ballbearing quiet, internal hinges Blum clips, metal handles, satin, brakes doors, baseboards painted.	CB-3	G.F.	1/1.7	1.8	0.6	2.75	1	4.95		
			F.F.	2/5.8 , 2/6.8	1.8	0.6	2.75	2	9.9		
5	CB-4- Wardrobe, furniture board laminated body, 18 mm MDF fronts 19 mm thick opaque matt lacquered drawers with full extension ballbearing quiet, internal hinges Blum clips, metal handles, satin, brakes doors, baseboards painted.	CB-4	G.F.	1/1.9	1.8	0.6	2.75	1	4.95		
6	CB-5- Wardrobe, furniture board laminated body, 18 mm MDF fronts 19 mm thick opaque matt lacquered drawers with full extension ballbearing quiet, internal hinges Blum clips, metal handles, satin, brakes doors, baseboards painted.	CB-5	G.F.	1/1.10	1.945	0.6	2.75	1	5.34875		

STAFF RESIDENCE CUPBOARDS

S.N.	DESCRIPTIONS	CB'S NAMES	FLOOR	ROOM-NO	SIZE			QUANTITY	AREA	RATE(€)	AMOUNT(€)
					WIDTH	DEPTH	HEIGHT				
7	CB-6- Wardrobe, furniture board laminated body, 18 mm MDF fronts 19 mm thick opaque matt lacquered drawers with full extension ballbearing quiet, internal hinges Blum clips, metal handles, satin, brakes doors, baseboards painted.	CB-6	F.F.	2/4.8, 2/7.8	1.63	0.6	2.75	2	8.965		
8	CB-7- Wardrobe, furniture board laminated body, 18 mm MDF fronts 19 mm thick opaque matt lacquered drawers with full extension ballbearing quiet, internal hinges Blum clips, metal handles, satin, brakes doors, baseboards painted.	CB-7	F.F.	2/4.5, 2/7.5	1.55	0.6	2.75	2	8.525		
9	CB-7A- Wardrobe, furniture board laminated body, 18 mm MDF fronts 19 mm thick opaque matt lacquered drawers with full extension ballbearing quiet, internal hinges Blum clips, metal handles, satin, brakes doors, baseboards painted.	CB-7A	F.F.	2/4.4, 2/7.4	1.35	0.6	2.75	2	7.425		
10	CB-L1- Wardrobe, furniture board laminated body, 18 mm MDF fronts 19 mm thick opaque matt lacquered drawers with full extension ballbearing quiet, internal hinges Blum clips, metal handles, satin, brakes doors, baseboards painted.	CB-L1	F.F.	2/4.2, 2/7.2	2.34	0.45	2.12	2	9.922		
11	CB-L2- Wardrobe, furniture board laminated body, 18 mm MDF fronts 19 mm thick opaque matt lacquered drawers with full extension ballbearing quiet, internal hinges Blum clips, metal handles, satin, brakes doors, baseboards painted.	CB-L2	G.F.	1/1.3,1/2.2 ,1/3.2	4.25	0.45	2.12	3	27.03		
			F.F.	2/5.2, 2/6.2	4.25	0.45	2.12	2	18.02		
			S.F.	3/8.2, 3/ 9.2	4.25	0.45	2.12	2	18.02		

STAFF RESIDENCE CUPBOARDS

S.N.	DESCRIPTIONS	CB'S NAMES	FLOOR	ROOM-NO	SIZE			QUANTITY	AREA	RATE(€)	AMOUNT(€)
					WIDTH	DEPTH	HEIGHT		SQM		
12	CB-1.1.1- Wardrobe, furniture board laminated body, 18 mm MDF fronts 19 mm thick opaque matt lacquered drawers with full extension ballbearing quiet, internal hinges Blum clips, metal handles, satin, brakes doors, baseboards painted.	CB-1.1.1	G.F.	1/1.1	1.47	0.46	2.75	1	4.0425		
13	CB-1.1.2- Wardrobe, furniture board laminated body, 18 mm MDF fronts 19 mm thick opaque matt lacquered drawers with full extension ballbearing quiet, internal hinges Blum clips, metal handles, satin, brakes doors, baseboards painted.	CB-1.1.2	G.F.	1/1.2	1.24	0.43	2.75	1	3.41		
14	CB-1.1.5- Wardrobe, furniture board laminated body, 18 mm MDF fronts 19 mm thick opaque matt lacquered drawers with full extension ballbearing quiet, internal hinges Blum clips, metal handles, satin, brakes doors, baseboards painted.	CB-1.1.5	G.F.	1/1.5	1.89	0.43	2.75	1	5.1975		
15	CB-1.2.1- Wardrobe, furniture board laminated body, 18 mm MDF fronts 19 mm thick opaque matt lacquered drawers with full extension ballbearing quiet, internal hinges Blum clips, metal handles, satin, brakes doors, baseboards painted.	CB-1.2.1	G.F.	1/2.1	1.46	0.6	2.75	1	4.015		
16	CB-1.3.1- Wardrobe, furniture board laminated body, 18 mm MDF fronts 19 mm thick opaque matt lacquered drawers with full extension ballbearing quiet, internal hinges Blum clips, metal handles, satin, brakes doors, baseboards painted.	CB-1.3.1	G.F.	1/3.1	1.46	0.6	2.75	1	4.015		
17	CB-1.3.3- Wardrobe, furniture board laminated body, 18 mm MDF fronts 19 mm thick opaque matt lacquered drawers with full extension ballbearing quiet, internal hinges Blum clips, metal handles, satin, brakes doors, baseboards painted.	CB-1.3.3	G.F.	1/3.3	1.14	0.35	2.1	1	2.394		

STAFF RESIDENCE CUPBOARDS

S.N.	DESCRIPTIONS	CB'S NAMES	FLOOR	ROOM-NO	SIZE			QUANTITY	AREA	RATE(€)	AMOUNT(€)
					WIDTH	DEPTH	HEIGHT				
18	CB-1/3.3- Wardrobe, furniture board laminated body, 18 mm MDF fronts 19 mm thick opaque matt lacquered drawers with full extension ballbearing quiet, internal hinges Blum clips, metal handles, satin, brakes doors, baseboards painted.	CB-1/3.3	F.F.	1/3.3	1.14	0.51	2.1	1	2.394		
19	CB-1/4.3- Wardrobe, furniture board laminated body, 18 mm MDF fronts 19 mm thick opaque matt lacquered drawers with full extension ballbearing quiet, internal hinges Blum clips, metal handles, satin, brakes doors, baseboards painted.	CB-1/4.3	F.F.	1/4.3	1.14	0.51	2.1	1	2.394		
20	CB-2/4.1- Wardrobe, furniture board laminated body, 18 mm MDF fronts 19 mm thick opaque matt lacquered drawers with full extension ballbearing quiet, internal hinges Blum clips, metal handles, satin, brakes doors, baseboards painted.	CB-2/4.1	F.F.	2/4.1	1.85	0.6	2.75	1	5.0875		
21	CB-2/5.1- Wardrobe, furniture board laminated body, 18 mm MDF fronts 19 mm thick opaque matt lacquered drawers with full extension ballbearing quiet, internal hinges Blum clips, metal handles, satin, brakes doors, baseboards painted.	CB-2/5.1	F.F.	2/5.1	1.46	0.6	2.75	1	4.015		
22	CB-2/5.3- Wardrobe, furniture board laminated body, 18 mm MDF fronts 19 mm thick opaque matt lacquered drawers with full extension ballbearing quiet, internal hinges Blum clips, metal handles, satin, brakes doors, baseboards painted.	CB-2/5.3	F.F.	2/5.3	1.14	0.51	2.1	1	2.394		
23	CB-2/6.1- Wardrobe, furniture board laminated body, 18 mm MDF fronts 19 mm thick opaque matt lacquered drawers with full extension ballbearing quiet, internal hinges Blum clips, metal handles, satin, brakes doors, baseboards painted.	CB-2/6.1	F.F.	2/6.1	1.46	0.6	2.75	1	4.015		

STAFF RESIDENCE CUPBOARDS											
S.N.	DESCRIPTIONS	CB'S NAMES	FLOOR	ROOM-NO	SIZE			QUANTITY	AREA	RATE(€)	AMOUNT(€)
					WIDTH	DEPTH	HEIGHT		SQM		
24	CB-2/7.1- Wardrobe, furniture board laminated body, 18 mm MDF fronts 19 mm thick opaque matt lacquered drawers with full extension ballbearing quiet, internal hinges Blum clips, metal handles, satin, brakes doors, baseboards painted.	CB-2/7.1	F.F.	2/7.1	1.83	0.6	2.75	1	5.0325		
25	CB-2/7.3- Wardrobe, furniture board laminated body, 18 mm MDF fronts 19 mm thick opaque matt lacquered drawers with full extension ballbearing quiet, internal hinges Blum clips, metal handles, satin, brakes doors, baseboards painted.	CB-2/7.3	F.F.	2/7.3	1.12	0.33	2.1	1	2.352		
26	CB-3/8.1- Wardrobe, furniture board laminated body, 18 mm MDF fronts 19 mm thick opaque matt lacquered drawers with full extension ballbearing quiet, internal hinges Blum clips, metal handles, satin, brakes doors, baseboards painted.	CB-3/8.1	S.F.	3/8.1	1.46	0.6	2.75	1	4.015		
27	CB-3/8.3- Wardrobe, furniture board laminated body, 18 mm MDF fronts 19 mm thick opaque matt lacquered drawers with full extension ballbearing quiet, internal hinges Blum clips, metal handles, satin, brakes doors, baseboards painted.	CB-3/8.3	S.F.	3/8.3	0.94	0.515	2.1	1	1.974		
28	CB-3/9.1- Wardrobe, furniture board laminated body, 18 mm MDF fronts 19 mm thick opaque matt lacquered drawers with full extension ballbearing quiet, internal hinges Blum clips, metal handles, satin, brakes doors, baseboards painted.	CB-3/9.1	S.F.	3/9.1	1.46	0.6	2.75	1	4.015		
29	CB-3/9.3- Wardrobe, furniture board laminated body, 18 mm MDF fronts 19 mm thick opaque matt lacquered drawers with full extension ballbearing quiet, internal hinges Blum clips, metal handles, satin, brakes doors, baseboards painted.	CB-3/9.3	S.F.	3/9.3	0.94	0.515	2.1	1	1.974		
Total front face area of Staff residences Cupboards									248.959		



**THE GOVERNMENT OF INDIA
MINISTRY OF EXTERNAL AFFAIRS**

**Fixed Furniture for Apartments and Chancery at the Embassy of India
UL. Mysliwiecka 2, 00-459, Warsaw**

PART – I TECHNICAL BID

Prime Consultants:

**Sachdev Eggleston Associates
G-33, First Floor, Kalka Ji
New Delhi 110 019, India**

INDEX

NAME OF WORK : **Fixed Furniture for Apartments and Chancery at
the Embassy of India, Ul. Mysliwiecka 2, 00-459, Warsaw**

	PAGES
1. TENDER NOTICE	03
2. INVITATIONS TO TENDER	04
3. INSTRUCTIONS TO TENDERERS	05-13
4. GENERAL CONDITIONS OF CONTRACT(FIDIC CONDITIONS)	14-101
5. PARTICULAR CONDITIONS OF CONTRACT	102-113
6. `APPENDIX TO TENDER`	114-115
ANNEXURES	
1. ANNEXURE 1 (BID PARTICULARS)	116
2. ANNEXURE 2 (FINANCIAL INFORMATION)	117
3. ANNEXURE 3 (BANKERS CERTIFICATE FOR SOLVENCY)	118
4. ANNEXURE 4 (AGENCY'S EXPERIENCE)	119
5. ANNEXURE 5 (EARNEST MONEY DEPOSIT DETAILS)	120
6. ANNEXURE 7 (PERFORMA OF CONTRACT AGREEMENT)	121-122
7. ANNEXURE 8 (BANK GUARANTEE FOR EMD)	123
8. ANNEXURE 9 (FORM OF PERFORMANCE SECURITY)	124
9. ANNEXURE 10 (BANK GUARANTEE IN LIEU OF RETENTION MONEY)	125
10. ANNEXURE 11,(MOBILIZATION ADVANCE PAYMENT GUARANTEE)	126
11. SCOPE OF WORK	127
12. TECHNICAL SPECIFICATIONS	128-131
13. LIST OF DRAWINGS	132

भारत का राजदूतावास , वार्सा
Embassy of India, Warsaw

No. WAR/862/2/2017

Date: 25.09.2017

PRESS NOTICE

The Head of Chancery, Embassy of India, Warsaw invites on behalf of President of India sealed tenders on a Two Part system (Part-I Technical Bid & Part-II Financial Bid) from Reputed Interior contractors in Warsaw for **Fixed Furniture for Apartments and Chancery** at the Embassy of India, Warsaw. The Tender Forms and other details can be downloaded from the website: www.indianembassywarsaw.in.

The last date of receipt of bid in the prescribed format with all enclosures and supporting documents in the office of Head of Chancery (HOC), **Embassy of India, Ul. Mysliwiecka 2, 00-459, Warsaw , Poland** will be 17 October 2017 up to 17:00 hrs.

Tel:00-48-22-5400009/20

Email: prop.warsaw@mea.gov.in

INVITATION TO TENDER

The Head of Chancery, Embassy of India, Warsaw on behalf of the President of India invites sealed bids in **two parts (Part I - Technical & Part II - Financial)** from Reputed Interior contractors in Warsaw for **Fixed Furniture for Apartments and Chancery** at the **Embassy of India, Ul. Mysliwiecka 2, 00-459, Warsaw , Poland**

1. **.NAME OF WORKS : Fixed Furniture for Apartments and Chancery at the Embassy of India, Ul. Mysliwiecka 2, 00-459, Warsaw , Poland**

Description of Works : High Quality Interiors works includes providing, making, fixing and, laying in position high quality **Fixed Furniture for Apartments and Chancery** at the Embassy of India at Warsaw.

Time Schedule:	06 Months
Earnest Money Deposit	Euro 8,500 [Euro Eight Thousand five Hundred
Tenders to be addressed to	Head of Chancery, Embassy of India, Ul. Mysliwiecka 2, 00-459, Warsaw , Poland
Last Date of Submission	17 October 2017 up to 17:00 hrs.
Place of Receipt of Tender	The Embassy of India, Warsaw
Date of Opening Tender	18 October 2017 at 15:30 hrs.
Tender Processing Fees	100_Euro. / (Non-Refundable)
Bid to remain valid:	180 days from the date of opening of the Tender.

2. Interested Bidders may obtain further information from the Head of Chancery, Embassy of India, Warsaw.
3. The bidding document can be downloaded directly from website www.indianembassywarsaw.in . The Technical Bid (Part I) and Financial Bid (Part II) must be enclosed in two separate envelopes. The Tender processing fees and the EMD as indicated above must also be enclosed in the envelope containing technical bid (Part I). The bids must reach this office on or before last date of submission.
4. The Eligibility Criteria are laid out in the Tender Documents which can be downloaded from www.indianembassywarsaw.in.
5. The technical bid(s) will be opened on 18 October 2017 in the **Embassy of India, Ul. Mysliwiecka 2, 00-459, Warsaw , Poland** in the presence of the tenderer(s) or their authorized representative(s) who are present at the scheduled date and time.
6. The date and time of opening of financial bid(s) will be decided after technical bid(s) have been evaluated by the Client. Financial bid(s) of only those tenderer(s) will be opened who qualify the technical evaluation on the specified date and time. The date, time & place of opening of the financial bid(s) will be intimated in due course of time.
7. The Embassy of India, Warsaw reserves the right to accept or reject any or all tenders either in part or in full without assigning any reasons thereof.
8. This INVITATION TO TENDER will form part of the Tender Documents

INSTRUCTIONS TO TENDERER

1. Eligibility Criteria:

The Agencies that fulfill the following requirements shall be eligible to apply. All documents required in support of eligibility along with the Tender Bid letter, Tender Document Fee and EMD and other documents enumerated below in Clause 7 (A) shall constitute the technical bid and will be submitted as Part - 1 (Technical Bid).

- i) The tenderer should be a reputed Interior Contractor with experience in performing similar works (High Quality Interior Works) in Warsaw.
- ii) The Tenderer should have executed at least one similar projects (High Quality Interior Works) of Euro 339,100 or two similar projects of Euro 211,950 or three similar projects of Euro 169,500 in the last 5 years.
- iii) Financial Eligibility.
 - i) Annual financial statement for last three years in Annexure 2. This should be supported by audited balance sheet and profit and loss account duly certified by a chartered Accountant, as submitted by the applicant to the Tax Department as applicable.
 - ii). The average annual turnover, on construction works, of the tenderer for the last three financial years ending December, 2016 shall not be less than Euro 211,900.
 - iii) The applicant should not have incurred loss on more than two years during the last five consecutive years ending December 2016. Certificate from the Chartered Accountant required.
 - iv) The applicant should have bank solvency of minimum Euro 169,500. Certificate from the Bank required in the format prescribed in the Annexure 3 of this document.

2. Earnest Money Deposit

- The bidder shall be required to deposit the earnest money (EMD) for an amount of Euro 8,500 payable by way of demand draft or an irrevocable Bank Guarantee from a scheduled bank in the prescribed format given as Annexure 8,
- If the EMD is submitted in the form of a demand draft, the demand draft shall be made in favor of Embassy of India, Warsaw.
- The successful Bidder's EMD will be discharged upon the Bidder furnishing the performance security. The EMD should be kept valid until then.
- The EMD may be forfeited:
 - (a) If a Bidder withdraws, modifies, revises, deviates, its bid during the period of bid validity or
 - (b) In case of a successful Bidder, if the Bidder fails to furnish order acceptance within 14 days and/or fails to furnish Performance Security at the time of entering into Contract.
- The EMD should be valid for a period of 180 days from the opening of tender.
- The Client is not liable to pay any interest on such an amount submitted as EMD.
- The earnest money deposit & tender processing fee must be enclosed in the envelope containing the technical bid. Any technical bid without earnest money deposit and tender processing fee will to be summarily rejected and the financial bid of such a bidder will not be opened.
- The earnest money deposit of the successful bidder shall be returned after the submission of the performance security.

- After the award of contract to the successful tenderer, the earnest money deposit of all the other Bidders shall be returned within 30 days. However, in case of delay no interest shall be payable.

3. Tender Processing Fee

- The Tender Processing Fee is Euro 100/- (Hundred Euro).
- The Tender Processing Fee is non refundable and is payable in the form of a demand draft drawn in favour of " Embassy of India, Warsaw "
- The Tender Processing Fee must be enclosed with Technical Bid (Envelope 1) failing which the bid will be summarily rejected and the Financial Bid (Envelope 2) of such bidder will not be opened.

4. Content of Bidding Documents

- The Works, Goods and Services required, bidding procedures and contract terms are prescribed in this bid document which includes the following: to be attested by the bidder)

Part-I Technical Bid

- (a) Tender Notice
- (b) Invitation to Tender
- (c) Instructions to Tenderers
- (d) General Conditions of Contract
- (e) Special Conditions of Contract
- (f) Appendix to Tender
- (g) Bid Particulars – Annexure-1
- (h) Financial Information – Annexure-2
- (i) Bankers' Certificate For Solvency – Annexure–3
- (j) Agency's Experience - Annexure-4
- (k) Earnest Money Deposit Details – Annexure-5
- (l) Performa of Contract Agreement – Annexure-7
- (m) Bank Guarantee for EMD – Annexure-8
- (n) Form of Performance Security – Annexure-9
- (o) Bank Guarantee in lieu of Retention Money – Annexure-10
- (p) Form of mobilization advance payment bank guarantee (Annexure 11)
- (q) Technical specifications

Part-II Financial Bid

- (s) Financial Bid Letter – Annexure- 6
- (t) Priced Schedule of Quantities (BOQ)

- The Bidder is expected to examine all instructions, forms, terms, and specifications in the bidding documents. Failure to furnish all information required by the bidding documents or submission of a bid not substantially responsive to the bidding documents in every respect will be at the Bidder's risk and may result in rejection of its bid.

5. Amendment of Bidding Documents

- At any time prior to the deadline for submission of bids, the Employer may, for any reason, whether at its own initiative or in response to a clarification requested by a prospective

bidder, modify the bidding documents by amendment.

- All prospective bidders who have received the bidding documents will be notified of the amendment in writing or by cable or by fax, or by e mail and will be binding on them.
- In order to allow prospective bidders reasonable time in which to take the amendment into account in preparing their bids, the Employer, at its discretion, may extend the deadline for the submission of bids.
- Any queries/clarifications regarding the contents of the Bidding Documents should be addressed to the Employer well in advance and should be received in this office not later than 15 days prior to the deadline for submission of bids. Queries may be submitted in Writing or by Email / Fax , but must be received by the Employer by the deadline given above.

6. Language of Bid

The bid prepared by the Bidder, as well as all correspondence and documents relating to the bid and exchanged by the Bidder and the Employer, shall be written in the **English language**.

7. Documents Comprising the Bid

The bid is required to be submitted in two parts. One part is the Technical Bid (Part I) and the second part is the Financial Bid (Part II).

- A. The Technical Bid (Part 1) prepared by the Bidder shall include the following without indicating the price in the bid form:

Part-I Technical Bid

- (a) Tender Notice
- (b) Invitation to Tender
- (c) Instructions to Tenderers
- (d) Conditions of Contract
- (e) Special Conditions of Contract
- (f) Appendix to Tender
- (g) Bid Particulars – Annexure-1
- (h) Financial Information – Annexure-2
- (i) Bankers' Certificate For Solvency – Annexure-3
- (j) Agency's Experience - Annexure-4
- (k) Earnest Money Deposit Details – Annexure-5
- (l) Performa of Contract Agreement – Annexure-7
- (m) Bank Guarantee for EMD – Annexure-8
- (n) Form of Performance Security – Annexure-9
- (o) Bank Guarantee in lieu of Retention Money – Annexure-10
- (p) Form of mobilization advance payment bank guarantee (Annexure-11)
- (q) Technical specifications

- B. The Financial Bid (Part 2) the priced bid shall comprise the techno commercial bid with price indicated and shall include the following documents.

Part-II Financial Bid

- (s) Financial Bid Letter – Annexure-6
- (t) Priced Schedule of Quantities (BOQ)

8 Rates:

- Rates should be quoted in Euro.

9. Period of Validity of Bids

- Bids shall remain valid for a period of 180 days from the opening date of the tender. A bid valid for a shorter period shall be rejected by the Employer.
- The overall offer for the assignment and tenderer(s) quoted price shall remain unchanged during the period of validity. In case the tenderer withdraws, modifies or change his offer during the validity period, bid is liable to be rejected and the earnest money deposit shall be fortified without assigning any reason thereof. The tenderer may be required to extend the validity of the bid and EMD.

10. Warranty / Guarantee / Defects Liability Period:

- The tender includes for and must be quoted with a 1 year Defects Liability Period on all works from the date of the practical completion.

11. Format and Signing of Bid

- The Bidder shall submit the item-wise bids in two separate envelopes. One envelope shall contain Technical Bid and the other shall contain the financial bid, superscribed accordingly.
- The original and all copies of the bid shall be typed or written in indelible ink and shall be signed by the Bidder or a person or persons duly authorized to bind the Bidder to the Contract. All pages of the bid, except for un-amended printed literature, shall be initiated by the person or persons signing the bid.
- Any interlineations, erasures or overwriting shall be valid only if the person or persons signing the bid initial them.

12. Sealing and Marking of Bids

- The bidder shall seal the Technical Bids and Financial Bids in two Separate envelopes duly marked as "Technical Bid" for **Fixed Furniture for Apartments and Chancery** at the Indian Embassy at Warsaw 2017 and "Financial Bid" for **Fixed Furniture for Apartments and Chancery** at the Indian Embassy at Warsaw 2017. Both the envelopes shall then be sealed in one outer envelope. The EMD and tender processing fee shall be submitted with Technical bids.
- The inner and outer envelopes shall:
 - (a) Be addressed to the Employer at the following address:
Head of Chancery
Embassy of India
Warsaw, Mysliwiecka 2, 00-459
 - (b) Bear the Tender No..... Date
- If the outer envelope is not sealed and marked as required, the Employer will assume no responsibility for the bid's misplacement or premature opening.
- Bids submitted by Telex, Cable, Fax or e-mail will be summarily rejected.

13. Deadline for Submission of Bids

- Bids must be received by the Employer at the address specified no later than the time and

date specified in the Invitation to Tender. In the event of the specified date for the submission of Bids being declared a holiday for the Employer, the Bids will be received up to the appointed time on the next working day.

- The Employer may, at its discretion, extend this deadline for submission of bids by amending the bid documents in which case all rights and obligations of the Employer and Bidders previously subject to the deadline will thereafter be subject to the deadline as extended.

14. Late Bids

- Any bid received by the Employer after the deadline for submission of bids prescribed by the Employer, will be summarily rejected and/or returned to the Bidders on demand.

15. Modification and Withdrawal of Bids (Prior to deadline only)

- The Bidder may modify or withdraw its bid after the bid's submission; provided that written notice of the modification or withdrawal is received by the Employer prior to the deadline prescribed for submission of bids.
- The Bidder's modification shall be prepared, sealed, marked and dispatched in accordance with the provisions of Clause 12.
- A withdrawal notice may be sent by fax or e mail but followed by a signed confirmation copy, post marked not later than the deadline for submission of bids.
- No bid may be modified subsequent to the deadline for submission of bids.
- No bid may be withdrawn in the interval between the deadline for submission of bids and the expiration of the period of bid validity specified by the Bidder on the bid form. Withdrawal of a bid during this interval may result in the Bidder's forfeiture of its EMD, pursuant to Clause 2.

16. Opening of Bids by the Employer

- The Employer will open all Technical Bids (PART 1), in the presence of Bidders representative with authority letter from bidder, who choose to attend, as per the schedule given in invitation to bids. Financial Bids of only those bidders found to be Eligible and Technically Qualified will be opened in the presence of Bidders representatives who choose to attend, on the date for opening of Financial Bids (Part 2) which will be intimated subsequent to the opening of the technical bids at the contact details available in bidders particular,(Annexure-1). The Bidders' representatives who are present shall sign the quotation opening sheet evidencing their attendance. In the event of the specified date of Bid opening being declared a holiday for the Employer, the Bids shall be opened at the appointed time and location on the next working day.
- The bidders' names, bid modifications or withdrawals, specifications, and the presence or absence of requisite bid security and such other details as the Employer, at its discretion, may consider appropriate, will be announced at the opening.
- In case a bidder has submitted a modified bid pursuant to Clause 15, The original bid will be considered withdrawn and the modified bid shall be considered.
- Any bid superseded and withdrawn pursuant to Clause 15 will not be opened and read out at bid opening and shall not be considered further for evaluation, irrespective of the circumstances.

17. Clarification of Bids

- During evaluation of bids, the Employer may, at its discretion, ask the Bidder for a clarification of its bid. The request for clarification and the response shall be in writing and no change in prices or substance of the bid shall be sought, offered or permitted. However, no negotiation shall be held except with the lowest bidder. The Employer shall give the clarification to the quarry raised by bidder. However, delay / failure by Employer to reciprocate the clarification of bidder shall not be the ground for delaying the tender process.

18. Preliminary Examination

- The Employer will examine the bids to determine whether they are complete, whether required sureties have been furnished, whether the documents have been properly signed, and whether the bids are generally in order.
- Arithmetical errors in the priced bids will be rectified on the following basis. If there is a discrepancy between the unit price and the total price that is obtained by multiplying the unit price and quantity, the unit price shall prevail and the total price shall be corrected. If the Contractor does not accept the correction of errors, its bid will be rejected. If there is a discrepancy between the price quoted in words and figures, the **rate quoted in words will be taken as final** and shall be binding on the agency.
- The Employer may waive any minor informality, non-conformity, or irregularity in a bid, which does not constitute a material deviation, provided such a waiver, does not prejudice or affect the relative ranking of any Bidder. Prior to the detailed evaluation, the Employer will determine the substantial responsiveness of each bid to the bidding documents. For purposes of these Clauses, a substantially responsive bid is one, which conforms to all the terms and conditions of the bidding documents without material deviations. Deviations from or objections or reservations to critical provisions such as those concerning Bid Security/ Performance Security, Warranty, Force Majeure, Applicable law and Taxes & Duties, etc., will be deemed to be a material deviation.
- If a bid is not substantially responsive, it will be rejected by the Employer and may not subsequently be made responsive by the Bidder by correction of the non- conformity. The Employer also reserves the rights to reject any conditional bids which vary from the terms and conditions specified in the Contract documents.

19. Contacting the Employer

- No Bidder shall contact the Employer on any matter relating to its bid, from the time of the bid opening to the time the Contract is awarded. If the bidder wishes to bring additional information to the notice of the Employer, it should do so in writing.
- Any effort by a Bidder to influence the Employer in its decisions on bid evaluation, bid comparison or contract award may result in rejection of the Bidder's bid.

20. Award Criteria

- The Employer will award the contract to the successful Bidder whose bid has been determined to be substantially responsive and has been determined to be the lowest evaluated bid.

21. Employer's right to vary Quantities at the Time of Award

- The Employer reserves the right at the time of Contract award to increase or decrease the quantity of goods and services originally specified in the Schedule of Requirements without any change in unit price or other terms and conditions and The Contract Price will be revised accordingly.

22. Employer's right to accept Any Bid and to reject any or All Bids

- The Employer reserves the right to accept or reject any bid, and to annul the bidding process and reject all bids at any time prior to award of Contract, without thereby incurring any liability to the affected Bidder or bidders or any obligation to inform the affected Bidder or bidders of the grounds for the Employer's action.

23. Notification of Award

- Prior to the expiration of the period of bid validity, the Employer will notify the successful bidder in writing by registered letter or fax or e-mail that the bid has been accepted by way of a Work Order.
- Upon the successful Bidder's furnishing of performance security pursuant to Clause 24, the Employer will generally notify each unsuccessful Bidder and will discharge its bid security, pursuant to Clause 2.

24. Performance Security

- Performance Security: The Contractor shall be required to furnish a performance Security at the time of entering into contract for the work order. The Performance Security shall be 5% of the accepted contract amount indicated in the letter of acceptance from a reputed Bank in Warsaw which is approved by the Employer. The Bank Guarantee shall be in the prescribed format as per Annexure – 9.
- The Performance Security as furnished by the Contractor shall remain valid for a period of sixty days beyond the date of the completion of all the contractual obligations of the Contractor under the contract
- Failure of the successful bidder to accept the order shall constitute sufficient grounds for the annulment of the award and forfeiture of the bid security and call for new bids.

25. Order Acceptance

- The successful bidder should submit Order acceptance of the work Order within 7 days from the date of issue of Award Letter, failing which it shall be presumed that the vendor is not interested and his bid security is liable to be forfeited.

26. Site

- The Site for the Works is at the **Embassy of India, Ul. Mysliwiecka 2, 00-459, Warsaw , Poland**

27. Secured Advance on Materials

- a) The Contractor shall be entitled to receive from the Employer a Secured Advance against an indemnity bond in the prescribed format to the Employer of such sum as the Engineer may consider proper in respect of non-perishable materials brought at the Site but not yet incorporated in the Permanent Works provided that:

The materials are in accordance with the Specifications for the Permanent Works;

Such materials have been delivered to the Site and are properly stored and protected against loss or damage or deterioration to the satisfaction of the Engineer but at the risk and cost of the Contractor;

The Contractor's records of the requirements, orders, receipts and use of materials are kept in a form approved by the Engineer, and such records shall be available for inspection by the Engineer;

The Contractor shall submit with his monthly statement the estimated value of the materials on Site together with such documents as may be required by the Engineer for the purpose of valuation of materials and providing evidence of ownership and payment thereof;

Ownership of such materials shall be deemed to vest in the Employer and these materials shall not be removed from the Site or otherwise disposed of without written permission of the Employer; and

The sum payable for such materials on Site shall not exceed **75%** of the cost of the ex factory / ex warehouse price of the materials , determined on the basis of sales receipts to the satisfaction of the Project Manager

- b) The recovery of Secured Advance paid to the Contractor under the above provisions shall be effected from the monthly payments on actual consumption basis.

28. Inspections and Tests

- The Employer or its representative shall have the right to inspect and/or to test the Materials, Works etc to confirm their conformity to the Contract specifications at no extra cost to the Employer.
- These Tests will be carried out as specified in the Technical Specifications which shall specify what inspections and tests if any, the Employer requires and where they are to be conducted. The Employer shall notify the Contractor in writing in a timely manner of the identity of any representatives retained for these purposes.
- Should any inspected or tested Works / Materials fail to conform to the specifications, the Employer may reject the Works / Materials and the Contractor shall either replace or make such alterations necessary to meet specification requirements free of cost to the Employer.
- Nothing in General Conditions of Contract shall in any way release the Contractor from any warranty or other obligations under this Contract.

29. Shop Drawings , Mockups and As Built Drawings

- It shall be the responsibility of the Contractor to make Shop Drawings for all works executed under this Contract and submit these drawings and submit them for Approval to the Project Manager well in advance of the Planned date for the Works.
- In case the specifications or the Project Manager instructs the preparation of a Mock Up , this will be executed well in time and will the cost of such Mockup will be deemed to have been included in the rates and nothing extra will be payable for such Mockups.
- Before the Works are taken over by the Employer; the Contractor shall prepare and supply the as built drawings to the Employer. These shall be in such detail to the satisfaction of the Project Manager as will enable the Employer to maintain all parts of the works as stated in the specifications.
- Unless and otherwise agreed, the Works shall not be considered to be completed for the purposes of taking over until such As Built Drawings have been supplied to the Employer.

30. Insurance

- The insurance shall be obtained by the Contractor to an amount equal to 115% of the Contract Price on "All Risks" basis including War Risks and Strikes. The insurance shall be valid for a period of not less than 2 months after the Completion Date .

SPECIAL CONDITIONS OF CONTRACT

Clause 1		
Sub Clause	1.3	<p>Communications</p> <p>The Following is added</p> <p>All such communications shall be directed in the first instance through the Project Manager at the Project Office the address of which is given in the Appendix to Contract</p>
Sub Clause	1.5	<p>Priority of Documents</p> <p>Delete Sub-Clause 1.5 and substitute:</p> <p>Contract Documents Complementary : The Contract documents are complementary and are intended to include or imply all items required for the proper execution and completion of the work. That required by any one shall be as binding as if required by all.</p> <p>In the event there are any discrepancies between individual documents / article/s, then whichever is the more stringent shall prevail. Any errors in description, quantity, or rate shall not vitiate the Contract or release the Contractor from the executions of the whole or any part of the work comprised therein, or any of his obligations under the Contract.</p> <p>In case of any disputes regarding the procedure of the document, the Project Manager's decision shall be binding on the contractor.</p>
	1.8	<p>Care and Supply of Documents</p> <p>The following is added</p> <p>All drawings supplied to the Contractor are deemed to be the property of the Architects. The Contractor agrees both on behalf of himself and his employees, and subcontractors, whether during or after completion of the contract not to divulge or use, except for the purpose of this contract, any information contained in the drawings.</p> <p>Execution as per Drawings: The Contractor must not vary or deviate from the drawings in any respect while executing the work or executing any extra work of any kind whatsoever unless advised by the Architects / Employer.</p>
Additional Sub Clause	1.12	<p>Following Sub Clause 1.12 : Notices is added</p> <p>Any notice given by one party to the other pursuant to this contract/order shall be sent to the other party in writing or by FAX or e mail and confirmed in writing to the other party's address specified in the Appendix to Tender.</p> <p>A notice shall be effective when delivered or on the notice's effective date, whichever is later.</p> <p>The Contractor shall comply with and give all notices required under any Government Authorities, instrument, rule of order made under any</p>

		Official Act, State Laws, or any regulation or bye-laws of any local Authority related to the work. The Contractor shall indemnify the Employer against any liability in respect of the above, without any additional cost.
Additional Sub Clause	1.13	<p>Following Sub Clause 1.1.3 is added</p> <p>The Contractor shall not, without the Employer's prior written consent, disclose the Contract, or any provision thereof, or any specification, plan, drawing, pattern, sample or information furnished by or on behalf of the Employer in connection therewith, to any person other than a person employed by the Contractor in performance of the Contract. Disclosure to any such employed person shall be made in confidence and shall extend only so far, as may be necessary for purposes of such performance.</p> <p>The Contractor shall not, without the Employer's prior written consent, make use of any such document or information except for purposes of performing the Contract.</p> <p>Any document, other than the Contract itself, shall remain the property of the Employer and shall be returned (in all copies) to the Employer on completion of the Contractor's performance under the Contract if so required by the Employer.</p> <p>The Contractor shall treat the details of the Contract as strictly private and confidential, except to the extent necessary to carry out obligations under it or to comply with applicable Laws. The Contractor shall not publish, permit to be published, or disclose any particulars of the Works in any trade or technical paper or elsewhere without the previous agreement of the Employer.</p>
Clause 4		
Sub-Clause	4.2	<p>Performance Security</p> <p>In Paragraph 2 line 1</p> <p>28 days is substituted by 14 days</p> <p>At the end of the second paragraph of Sub-Clause 4.2, insert:</p> <p>The Performance Security shall be in the form of a Bank Guarantee in an approved form as per Annex -9, as indicated in the Letter of Acceptance. The Bank Guarantee shall be from a reputed Bank in Warsaw which is approved by the Employer.</p>
Sub Clause	4.3	<p>Contractor's Representative</p> <p>At the end of Sub-Clause 4.3, add:</p> <p>The Contractor's Representative and all these persons shall also be fluent in English.</p>
Sub Clause	4.4	<p>Subcontractors</p> <p>The following is added</p> <p>Assignment :The contractor shall not assign the contract or any part thereof or any benefit therein or there under without the written permission of the Project Manager/ Employer.</p> <p>Sub-letting: The contractor shall not sub-let the whole of the contract. The contractor shall not sublet any part of the works without the written consent of the Employer and such consent if given, shall not release the Contractor from any liability or obligation under the contract</p>

		<p>and the Contractor shall be responsible for the acts, defaults and neglects of the Subcontractor, his agents, employees or workmen as fully as if they were the acts defaults or neglect of the Contractor or his agents, servants, or workmen</p> <p>All guarantees of works furnished by the specialised agencies/sub-contractors shall be submitted to Project Manager / Employer.</p> <p>The Contractor shall require of its Subcontractor - where previously approved by the Project Manager to agree in writing with the Contractor to be bound to Contractor by the terms of the Contract Documents that apply to the subcontracted work, and to assume towards the Contractor all of the obligation and responsibilities that the Contractor by the contract documents assumes towards the Employer, and Architect</p>
--	--	---

APPENDIX TO TENDER

Item	Clause	Data
Employer's name and address	1.1.2.2 & 1.3	The President of India represented through the Embassy of India, Ul. Mysliwiecka 2, 00-459, Warsaw , Poland
Contractor's name and address	1.1.2.3 & 1.3	
Engineer's name and address	1.1.2.4 & 1.3	Sachdev Eggleston Associates G-33, First Floor Kalkaji New Delhi-110019, INDIA
Commencement of works	1.1.3.2 & 8.1	Within 15 Days after the Contractor receives the letter of Acceptance
Time for Completion of the works	1.1.3.3	180 calendar days
Defects Liability Period	1.1.3.7 & 11.1	365 days after actual date of completion, to be certified by Engineer and accepted by the employer
Governing Law	1.4	Warsaw
Ruling Language	1.4	English
Language for communications	1.4	English
Amount of Performance Security	4.2	Five per cent (5%) of the Accepted Contract Amount
Delay damages for the works	8.7 & 14.15 (b)	0.5 % of Accepted Contract Amount per week of delay
Maximum amount of delay damages	8.7	Ten per cent (10%) of the Accepted Contract Amount
Advance payment,	14.2	10% of contract amount @10% simple interest against Bank Guarantee of equivalent amount
Minimum amount of Interim Payment Certificates	14.6	Twenty per cent (20%) of the Accepted Contract Amount or Minimum one RA bill in two months on submission by Contractor
Retention	14.9	5% of the contract amount
Currency/Currencies of payment	14.15	Euro (***)
Minimum amount of insurance of works	18	The insurance shall be obtained by the contractor to the amount equal to 115% of the contract price.
Insurance of Contractor Personnel	18.4	As per local Bye-laws
Claims, disputes and	20.1	Any dispute in connection with

arbitration		agreement shall be settled in accordance with provision of UNCITRAL (United Nations Commission of International Trade Law) Arbitration rules 1976.

Signature of Contractor

Date: _____

Bidders Particulars

Tender No.....

a) Name of the Bidder

b) Address of the Bidder

Telephone Nos.

Landline:

Mobile:

Fax

E- mail

c) Date of Inception:

d) Name and Address of the officer to whom all references shall be made regarding this tender:

Telephone Nos.

Landline:

Mobile:

Fax

E-mail

Signature.....

Name.....

Designation.....

Date.....

Company Seal.....

Annexure 2

Financial Information

Details to be furnished duly supported by figures in balance sheet / profit & loss account for the last five years duly certified by the Chartered Accountant.

Years

i) Gross Annual Turnover on Construction Works.

ii) Profit / Loss

Signature of Chartered Accountant with Seal

Signature of Bidder

Form of Bankers Certificate for Solvency

This is to certify that to the best of our knowledge and information that M/s / Mr. _____
_____ a customer of our bank are / is
respectable and can be treated as good for any engagement up to a limit of Euro _____
(_____ only).

This certificate is issued without any guarantee or responsibility on the bank or any of the Officers.

(Signature for the Bank)

Note :

- i) Bankers Certificate should be on letter head of the Bank, Sealed in cover addressed to tendering authority.
- ii) In case of partnership firm, certificate should include names of all partners as recorded with the bank.

Technical Bid

Agency's Experience

Project Details where such works have been undertaken and successfully completed during the last five years ending the last day of the financial year i.e. December, 2016.

Name & Address of Client	Type of Client	Address	Years	Details of Items supplied / commissioned	Quantity	Approximate value of Items (in Euro)	Name, title and Contact details of the contact at : Client location	Agency Signature, Name, Designation & Company Seal

Note: Documentary evidence in respect of each client to be enclosed.

Annexure 5

Technical Bid

Earnest Money Deposit Details

(Please give the details of the earnest Money Deposit of Euro _____ (_____)).

Amount :

Demand Draft No. :

Drawee Bank / Branch :

Date :

Annexure 7

PERFORMA OF CONTRACT AGREEMENT

This Agreement made at _____ on the _____ of _____ 20_____.

Between the **President of India represented through The Embassy of India, Ul. Mysliwiecka 2, 00-459, Warsaw , Poland** hereinafter called 'the Employer ') of the one part, And _____ (hereinafter called 'the Contractor') of the other part

Whereas the Employer desires that the Works : **Fixed Furniture and Kitchen Cabinetry for Apartments and Chancery at the Embassy of India, Ul. Mysliwiecka 2, 00-459, Warsaw , Poland** should be executed by the Contractor, and has accepted a Tender by the Contractor for these Works as per the terms and conditions of Contract documents .

The Employers and the Contractor agree as follows:

1. In this Agreement words and expressions shall have the same meanings as are respectively assigned to them in the Conditions of Contract hereinafter referred to.
2. The following documents shall be deemed to form and be read and construed as part of this Agreement:

Part-I Technical Bid

- (a) Tender Notice
- (b) Invitations to Tender
- (c) Instructions to Tenderers
- (d) General Conditions of Contract
- (e) Special Conditions of Contract
- (f) Appendix to Tender
- (g) Bid Particulars – Annexure-1
- (h) Financial Information – Annexure-2
- (i) Bankers' Certificate For Solvency – Annexure-3
- (j) Agency's Experience - Annexure-4
- (k) Earnest Money Deposit Details – Annexure-5
- (l) Performa of Contract Agreement – Annexure-7
- (m) Bank Guarantee for EMD – Annexure-8
- (n) Form of Performance Security – Annexure-9
- (o) Bank Guarantee in lieu of Retention Money – Annexure-10
- (p) Form of Mobilization advance payment bank guarantee (Annexure-11)
- (q) Technical Specifications

Part-II Financial Bid

- (s) Financial Bid Letter – Annexure-6
- (t) Priced Schedule of Quantities (BOQ)

3. In consideration of the payments to be made by the Employer to the Contractor as hereinafter mentioned, the Contractor hereby covenants with the Employer to Execute the Works described in these contract conditions and remedy any defects therein, in conformity with the provisions of the Contract.

4. The Employer hereby covenants to pay the Contractor, in consideration of the execution of the Works in accordance with the terms and conditions of the contract and the remedying of defects therein, the Contract Price at the times and in the manner prescribed by the Contract.

In Witness whereof the parties hereto have caused this Agreement to be executed the day and year first before written in accordance with their respective laws.

SIGNED by: for and on behalf of the Employer in the presence of Witness: Name: Address: Date:		SIGNED by: for and on behalf of the Contractor in the presence of Witness: Name: Address: Date:
--	--	--

BANK GUARANTEE FOR EMD

Between the President of India represented through _____ The Embassy of India at Warsaw, Poland hereinafter called 'the Employer ') of the one part, And _____ (hereinafter called 'the Contractor') of the other part

Whereas the Bidder has submitted his bid dated _____ for the work: **Fixed Furniture for Apartments and Chancery** at the **Embassy of India, Ul. Mysliwiecka 2, 00-459, Warsaw , Poland** hereinafter called "the Bid".

KNOW ALL MEN by these presents that we _____ hereinafter called "the Bank" are bound unto the Employer in the sum of Euro _____ for which payment will and truly to be made to the said Employer, the Bank binds himself, his successors and assigns by these presents.

Sealed with the common seal of the said Bank this _____ day of 20_____.

The CONDITIONS OF these obligations are:-

If the Bidder withdraws his bid during the period of bid validity specified in the Tender or
If the bidder does not accept the correction of arithmetical errors of his Bid Price or
If the Bidder having been notified the acceptance of his Bid by the Employer during the period of Bid Validity. Fails or refuses to execute the Form of Agreement in accordance with the tender conditions, if required or Fails or refuses to furnish the Performance Security, in accordance with the Tender conditions.

We undertake to pay the Employer up to the above amount upon receipt of his first written demand without the Employer having to substantiate his demand provided that in his demand the Employer will note that the amount claimed by him is due to him owing to the occurrence of one or any of the conditions specifying the occurred condition or conditions.

This guarantee will remain in force up to and including the date for 180 days after the deadline for submission of bids. Any demand in respect of this Guarantee should reach the Bank not later than the above mentioned period.

Not WITHSTANDING anything contained herein above.

1. Our liability under this Guarantee shall not exceed Euro _____ (_____).
2. The Bank Guarantee shall be valid up to and including _____ day of _____ 20 .
3. We shall be liable to pay the Guarantee amount or any part thereof under this Bank Guarantee only and only if you serve upon us a written claim or demand on or before _____ day of _____ 20_.

Date:

Signature of Bank

Seal of Bank

Signature of witness

Name & Address of witness

FORM OF PERFORMANCE SECURITY (GUARANTEE)
BANK GUARANTEE

In consideration of the President of India represented through The Ambassador, Indian Embassy at Warsaw (hereinafter called "The EMPLOYER") having offered to accept the terms and conditions of the proposed agreement between the Employer and _____ (hereinafter called "the Contractor" for the work "**Fixed Furniture for Apartments and Chancery** at the **Embassy of India, Ul. Mysliwiecka 2, 00-459, Warsaw , Poland**

(hereinafter called "the said agreement") having agreed to production of an irrevocable Bank Guarantee for Euro _____ (Only) as a security / guarantee from the Contractor for compliance of his obligations in accordance with the terms and conditions in the said agreement.

We _____ (hereinafter referred to as "the Bank") hereby undertake to pay to the Employer an amount not exceeding Euro _____ (_____ Only) on demand by the Employer.

2. We, the said Bank, do hereby undertake to pay the amounts due and payable under this guarantee without any demure, merely on a demand from the Employer stating that the amount claimed as required to meet the recoveries due or likely to be due from the said Contractor. Any such demand made on the bank shall be conclusive as regards the amount due and payable by the bank under this Guarantee. However, our liability under this guarantee shall be restricted to an amount not exceeding Euro _____ (_____ Only).

3. We, the said bank, further undertake to pay the Employer any money so demanded notwithstanding any dispute or disputes raised by the Contractor in any suit or proceeding pending before any court or Tribunal relating thereto, our liability under this present being absolute and unequivocal.

4. We, the said Bank, further agree that the guarantee herein contained shall remain in full force and effect during the period that would be taken for the performance of the said agreement and that it shall continue to be enforceable till all the dues of the Employer under or by virtue of the said agreement have been fully paid and its claims satisfied or discharged or till Engineer on behalf of the Employer certified that the terms and conditions of the said agreement have been fully and properly carried out by the said Contractor and accordingly discharges this guarantee.

5. We, the said Bank, further agree with the Employer that the Employer shall have the fullest liberty without our consent and without affecting in any manner our obligation hereunder to vary any of the terms and conditions of the said agreement or to extend time of performance by the said Contractor from time to time or to postpone for any time or from time to time any of the powers exercisable by the Employer against the said Contractor and to forbear or enforce any of the terms and conditions relating to the said agreement and we shall not be relieved from our liability by reason of any such variation, or extension being granted to the said Contractor or for any forbearance, act of omission on the part of the Employer or any indulgence by the Employer to the said Contractor or by any such matter or thing whatsoever which under the law relating to sureties would, but for this provision, have effect of so relieving us.

6. This guarantee will not be discharged due to the change in the constitution of the Bank or the Contractor.

7. We, the said Bank, lastly undertake not to revoke this guarantee except with the previous consent of the Employer in writing.

8. This guarantee shall be valid up to ___ unless extended on demand by the Employer. Notwithstanding anything mentioned above, our liability against this guarantee is restricted to Euro _____ (_____ only) and unless a claim in writing is lodged with us within six months of the date of expiry or the extended date of expiry of this guarantee all our liabilities under this guarantee shall stand discharged.

Date:

Signature of Bank

Seal of Bank

Signature of witness

Name & Address of witness

Bank Guarantee in lieu of Retention Money

Brief description of contract _____

Name and address of Beneficiary the **Embassy of India, Ul. Mysliwiecka 2, 00-459, Warsaw , Poland .**

We _____ (name of bank) have been informed that _____(hereinafter called the “Principal”) is your Contractor under such Contract and wishes to receive early payment of [part of] the retention money, for which the contract requires him to obtain a guarantee.

At the request of the principal, we (name of bank) _____ hereby irrevocably undertake to pay you, the Beneficiary /Employer, any sum or sums not exceeding in total the amount of _____(in words) (the “guaranteed amount”) upon receipt by us of your demand in writing and your written statement stating:

a) That the principal has failed to carry out his obligation(s) to rectify certain defect(s) for which he is responsible under the contract;

Or

b) The principal is liable to pay compensations or the sums of money to the beneficiary/employer as per the contract conditions;

Or

c) The amount claimed is required to meet the recoveries due or likely to be due from the principal as per contract conditions.

We _____(name of bank), further undertake to pay the Beneficiary/Employer any sum not exceeding the guaranteed amount so demanded notwithstanding any dispute or disputes raised by the principal in any suit or proceeding pending before any court or Tribunal relating thereto out liability under the present being absolute and unequivocal.

We _____ (name of bank) further agree with the beneficiary/employer that the beneficiary/employer shall have the fullest liberty without our consent and without affecting in any manner our obligation hereunder to vary any of terms and conditions of the said contract or to extend time of performance by the said principal from time to time or to postpone for any time or from time to time any of the powers exercisable by the Beneficiary /Employer against the said principal and to forbear or enforce any of the terms and conditions relating to the said extension being granted to the said principal or for any forbearance, act of any omission on the part of the Beneficiary/Employer or any indulgence by the Beneficiary/Employer to the said principal or by any such matter or thing whatsoever which under the law relating to sureties would, but for the provision, have effect of so relieving us.

The Bank Guarantee will not be discharged due to the change in the constitution of the Bank or the principal.

We _____(name of bank) lastly undertake not to revoke this Bank Guarantee except with the previous consent of the Beneficiary/Employer in writing.

The demand for payment must be received by at this office on or before _____(valid up to completion period plus defect liability period of _____year/s along with claim-up period of three months).

We _____(name of bank) have been informed that the Beneficiary/Employer may require the principal to expend this Bank Guarantee if the taking over certificate has been issued prior to such expiry date we under tank to pay Beneficiary/Employer such bank guarantee amount upon receipt by us within such period of your demand in writing on or before _____and your written statement that the taking over certificate has not been issued from reasons attributable to the principal and this bank guarantee has not been extended.

Date _____

Signature(s) _____

FORM OF MOBILIZATION ADVANCE PAYMENT BANK GUARANTEE

Brief description of Contract: **Fixed Furniture for Apartments and Chancery at the Embassy of India, Ul. Mysliwiecka 2, 00-459, Warsaw , Poland.**

Name and address of Beneficiary: The President of India represented through The Ambassador, Embassy of India at Warsaw (whom the Contract defines as the Employer).

We _____ (name of bank) have been informed that _____(hereinafter called the 'Principal') is your contractor under such Contract and wishes to receive an advance payment, for which the Contract requires him to obtain a guarantee.

At the request of the Principal, we _____(name of bank) hereby irrevocably undertake to pay you, the Beneficiary/Employer, any sum or sums not exceeding in total the amount of Euro_____ (_____ only), the 'guaranteed amount' upon receipt by us of your demand in writing and your written statement stating:

- (a) That the Principal has failed to repay the advance payment in accordance with the conditions of the Contract, and
- (b) The amount which the Principal has failed to repay.

This guarantee shall become effective upon receipt of the advance payment by the Principal. Such guaranteed amount shall be reduced by the amounts of the advance payment repaid to you, as evidenced by your payment notices as per the Conditions of the Contract. Following receipt (from the Principal) of a copy of each purported notice, we shall promptly notify you of the revised guaranteed amount accordingly.

Any demand for payment must contain your signature(s) which must be authenticated by your bankers or by a notary public. The authenticated demand and statement must be received by us at this office on or before (the date 60 days after the expected expiry of the Time for Completion) _____ (the 'expiry date'), when this guarantee shall expire and shall be returned to us.

We have been informed that the Beneficiary may require the Principal to extend this guarantee if the advance payment has not been repaid by the date 28 days prior to such expiry date. We undertake to pay you such guaranteed amount upon receipt by us, within such period of 28 days, of your demand in writing and your written statement that the advance payment has not been repaid and that this guarantee has not been extended.

This guarantee shall be governed by the laws of Warsaw and shall be subject to the Uniform Rules for Demand Guarantees, published as number 458 by the International Chamber of Commerce, except as stated above.

Date:
Signature of Bank
Seal of Bank
Signature of witness
Name & Address of witness

TECHNICAL SPECIFICATIONS

1. GENERAL

A. Scope of work

1. The work covered under this section of Specification consists of providing all material, labour, plant equipment appliances and performing all operations conducted with the fabrication and erection of all woodwork, millwork, construction, assembly, surface finish treatment and building in of all cabinet type items, supports, etc. of wood or metal and incidentals, associated woodwork appurtenances, procuring and applying preservatives, installation of “ Finish hard Ware” in connection with finish woodwork as per details shown on the drawings or as this section is covered with detailed specifications as laid down herein.
2. This Section includes all required fixtures, anchors, adhesives and related accessories, Contractor shall provide all miscellaneous metal, which is laid shown on or implied by the drawings and required for the work.
3. The Contractor to structurally design the supporting systems for wood ceiling to ensure the safety and stability of the system and submit the shop drawings and calculations for review before fabrication.
4. Fire Code – Fire Hazard classification shall be determined by ASTM – E 64. Flame proofing certificates and / or test.
Data result from the manufacturer for each piece of fabric shall be delivered to the owner for approval at the time of submission of samples.

B. SUBMITTALS

1. **Product Data** : For each type of product and process specified and incorporated in to items of wood work during fabrication, finishing and installation.
 - a) Include source of wood to be used.
 - b) Include data for wood-preserved treatment instructions for handling, storing, installing, and finishing treated material.
2. **Shop Drawings**: Show location of each item, dimensioned plans and elevations, large-scale details, attachment devices, and other components.
 - a) Show details full size.
 - b) Show locations and sizes of blocking and nailers, including concealed blocking and reinforcement specified in other Sections.
3. **Samples for Verification**:
 - a) Lumber products for applied finish, 300 sq. cm for lumber, for finish system and colour, with 1/2 of exposed surface finished.
 - b) Include 150 mm long samples for each application.
 - c) Veneer leaves representative of and selected from flitches to be used.
 - d) Wood-veneer – faced panel products, 300 * 300 mm.
4. **Mockups** : Before fabricating and installing architectural woodwork, build mockups for each form of construction and finish required as directed to verify selections

made under sample submittals and to demonstrate aesthetic effects and qualities of materials and execution.

5. Approved mock-ups may become part of the completed work if undisturbed at time of Substantial Completion.

C. APPLICABLE STANDARDS

1. Latest editions of following British and ASTM standard are relevant to these specifications wherever applicable.
 - a) The Structural Use of Timber in Buildings.
 - (1) BS 459-65 Match boarded doors
 - (2) BS 565-72 Glossary of Terms Relating to Timber and Woodwork
 - (3) BS 1186-71 Quality of timber and workmanship in joinery
 - (4) BS 1202-74 Nails
 - (5) BS 1203-79 Specifications for synthetic resin adhesive for plywood
 - (6) BS 1204-79 Synthetic resin adhesives for wood
 - (7) BS 1210-63 Wood screws
 - (8) BS 1282-75 Guide to the choice, use and application of wood preservatives
 - (9) BS 1455-72 Plywood manufactured from tropical hardwoods
 - (10) BS 1579-60 Connectors for timber
 - (11) BS 3444-72 Block Board and Laminated Board
 - (12) BS 3842-65 Treatment of plywood with preservatives
 - (13) BS 5268 Preservative Treatment for Constructional Timber
 - (14) Pt.5 1977

D. TOLERANCES

1. -Size: Plus or minus 1.6 mm overall dimensions
2. -Maximum warp: 6 mm
3. - Square ness: Maximum diagonal difference 3 mm (between length of diagonal measured on face of door or window from upper right corner to lower left corner and length of diagonal measured from upper left corner to lower right corner).

E. DELIVERY AND STORAGE

1. Deliver and store products in waterproof, protective containers with seals unbroken and labels intact until time to use.
2. Keep products dry, stack products off ground on level platform, fully protected from weather, including direct sunlight.
3. Identify type, size and location of each door ventilator before delivery in order to permit installation at correct location.
4. All materials and assembled units are to be protected from weather and stored in such a way as to prevent decay and attack by fungus and termites.

II. PRODUCTS

A. TIMBER

1. GENERAL CHARACTERISTICS

- a) The timber shall be in accordance with the requirements of BS: 1186 'Quality of Timber and Workmanship in Joinery', Part 1, 'Quality of Timber'.
- b) First quality timber shall be from the heart of a sound tree, the sap wood being entirely removed, the wood being uniform in substance, straight in fiber, free from large or dead knots, flaws, snakes or blemishes of any kind. The colour of good timber shall be uniform throughout and among coloured timbers darkness of colour is an apparent indication of strength and durability.
- c) For first quality teak wood, the size of the knot shall not be more than 13 mm (1/2") and there should not be more than one knot in every 10 Sft. Of timber.

2. SEASONING OF TIMBER

- a) Timber shall be properly seasoned. It shall be kiln or air dried to reduce the moisture content to a maximum of 15% of its natural weight. All timber shall have moisture content acceptable according to its nature and usage as approved by the Engineer.

3. HARD AND SOFT WOOD

- a) Door frames, glazed, semi glazed and paneled shutters and core of flush doors shall be made in hard wood unless otherwise specified.
- b) Softwood consists of deodar chili, partal and maranti. Unless otherwise specified or allowed by the Engineer only deodar wood shall be used for softwood. Hardwood consists of Shisham, Teak, Iroko, Walnut, beach or oak whichever specified.

4. PRESERVATION OF WOOD

- a) All timber shall be protected with an organic solvent water repellent wood preservative to give a highly efficient protection against termite, spider, worm, all insect and fungus and rot attack and shall, where exposed, enhance the appearance of the timber. Colour of the product shall be such as to bring out the natural colour of the respective timbers. The preservative shall penetrate deeply into the timbers, shall protect against blue stain, rot, fungus, and termite spider, worm, all insect attack and shall contain a resin which fixes the preserving agent and protects them against leaching and evaporation.

B. PLYWOOD AND VENEER

1. GENERAL

- a) BS : S65 Section 5, ‘ Glossary of Terms Applicable to Plywood’, defines plywood as ‘an assembled product made up of plies and adhesives, the chief characterisitic being the crossed plies which distribute the longitudinal wood strength. The term plywood in general sense includes similar products such as laminated board, block board and batten board. BS: 1455 shall be used for acceptable standards of plywood.

2. THREE PLY AND MULT-PLY WOOD

- a) Three ply construction includes a ‘face’, a ‘back’ and a core of inner ply. Multi-ply includes a face, a back and a core of three or more inner plies. With very few exceptions the grain of each veneer in the core runs at right angles to that of the veneers on the either of it.
- b) The construction of plywood may be balanced with an odd number of veneers arranged symmetrically or unbalanced. The tendency of the finished board to distort is reduced by adopting a balanced construction.
- c) The construction may vary for a given panel thickness by the inclusion of veneers of various thickness. This will affect the strength properties.

3. INTERIOR AND RESIN BONDED

- a) Plywood according to BS: 1455 is classified into two main types, viz interior and resin bonded.
- b) Interior type plywood is suitable for most interior work including flush door panels, and any location where resistance to moisture is not required. Adhesive used include casein , soya, blood albumen and animal glues as well as synthetic resin extended with other substances.
- c) Synthetic resin bonded plywood while being suitable for the same purpose as interior type, as a much greater resistance to moisture. The more resistant types are suitable for external flush doors and door panels.
- d) Shop front facias, and for any purpose where it may be exposed to moisture. Adhesives used include urea, melamine phenol and resorcinol formaldehyde (arranged in order of increasing moisture resistance).

4. VENEER

- a) Grade I Veneer shall be of one piece of form smoothly cut veneer. The veneers shall be free from knots, worm and beetle holes, splits, dots, glue-stains, filing or inlaying of any kind or other defects. No end joints are permissible.

- b) Grade II Veneer shall present a solid surface free from open defects. Veneer may be in one or two pieces. Pieces of Veneers when jointed need not necessarily be matched for colour or be of equal width. A few sound knots are permitted with occasional minor discoloration and slight glue stains, isolated pin holes not along the plane of the veneer.
- c) The uses, for which plywood made with the grades defined above are considered useful, are outlined hereunder:
- d) Grade I For use in its natural state
- e) Grade II For use where subsequent painting and /or veneering is intended.

5. LAMINATED BOARD

- a) This is built-up board, with narrow strip 3 to 7 mm wide, faced both sides with either one or two veneers from 1.2 mm to 3.7 mm thick. Where single or double face veneers are used, the grain usually runs at right angles to the grain of the core strip. This type of board when available varies between 13 mm to 25 mm in thickness and is an ideal base for the highest class of veneered wood . For detailed specifications' BS 3444 'Block Board and Laminated Board' shall be used.

6. BLOCK BOARD

- a) This board conforming to BS 3444 is of similar construction to laminated board but core is built-up of blocks up to 25 mm wide. It is used as a base for veneering and for painted work but is considered slightly inferior to laminated board for the former use. The range of size and thicknesses in which it is manufactured are similar to those of laminated board.

C. ADHESIVES

- a) For joiners work animal glues complying with BS: 745, 'Animal glues for Wood' or synthetic resin adhesive complying with BS: 1204, 'Cold Setting Synthetic Resin Adhesives for Construction Work in Wood' shall be used. For flush doors and other forms of construction that rely mainly upon the adhesive, and particularly where exposure conditions are severe and prolonged dampness is likely to occur, one of the more moisture resistant adhesives shall be employed, the choice depending upon the severity of the conditions to which the work will be exposed.

D. DECORATIVE

Brass / Copper, Wire Inlay Works

LIST OF DRAWINGS

S. No	Name Of Block	Drawings No
1.	Kitchen for the Chancery	1
2.	Kitchen for the residences	2
3.	Fixed furniture for the residences	3